

FCC Registered DAA Module with DTMF Transmitter/Decoder

Description

The XE0068DT is an FCC registered telephone line interface which includes a DTMF transmitter, DTMF decoder and call progress monitor.

FCC rules limit the signal level that equipment can place on the telephone line. The XE0068DT incorporates an Automatic Gain Control (AGC) circuit to control the output signal level. The AGC optimizes the output level over a wide variety of input levels without introducing signal distortion.

FCC rules also dictate a 2-second delay at the start of each call. This billing delay prevents information transmission during the billing period. The XE0068DT includes this billing delay.

The integrated DTMF transceiver, call progress monitor and FCC registration make the XE0068DT ideal for network signalling applications.

Features

- * Small Size - 2.28" x 1.08" x 0.42"
- * User Transferrable FCC Part 68 Registration
- * Integrated Ring Detection Circuit.
- * Solid-State Hookswitch Control
- * Provides 1500 Volt Isolation between the telephone line and all other circuits
- * Includes supplemental surge protection to survive both FCC Type A and Type B surges.
- * Integral 2-Second Billing Delay (required for FCC Part 68 registration)
- * Automatic Gain Control optimizes transmit level for most any input level.
- * Integral DTMF transmitter and decoder
- * Call Progress Monitoring

XE0068DT Block Diagram

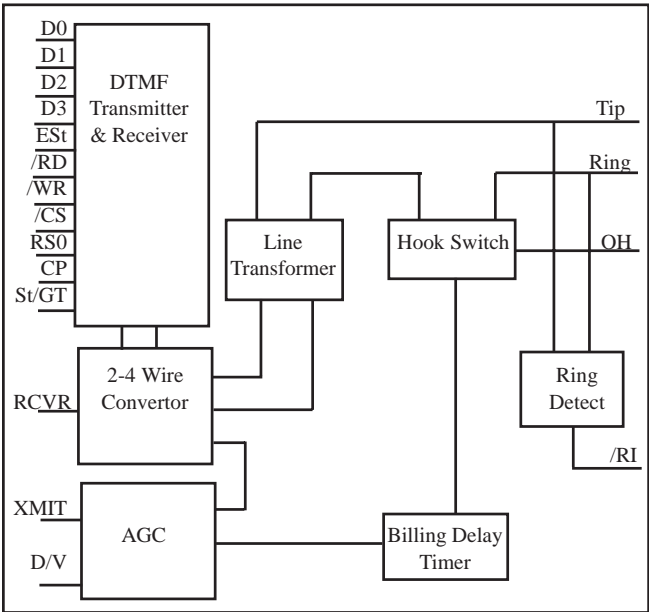

XE0068DT Pin Configuration

VCC	o 1	26	o	Tip
D3	o 2			
D2	o 3	24	o	Ring
D1	o 4			
D0	o 5	22	o	/RI
/WR	o 6	21	o	OH
/RD	o 7	20	o	N/C
/CS	o 8	19	o	RCVR
RS0	o 9	18	o	XMIT
N/C	o 10	17	o	St/GT
N/C	o 11	16	o	ESt
N/C	o 12	15	o	CP
D/V	o 13	14	o	GND

XE0068DT Mechanical Specifications

Dim	Inches		Metric(MM)	
	Min	Max	Min	Max
A	2.270	2.290	57.66	58.17
B	1.065	1.095	27.05	27.81
C	0.420	0.430	12.32	13.08
D	0.890	0.910	22.61	23.11
E	1.190	1.210	30.23	30.73
F	0.125	0.200	3.18	5.08
G	0.080	0.100	2.03	2.54
H	0.530	0.550	13.46	13.97
J	0.090	0.110	2.29	2.79
K	0.020	0.025	0.51	0.64

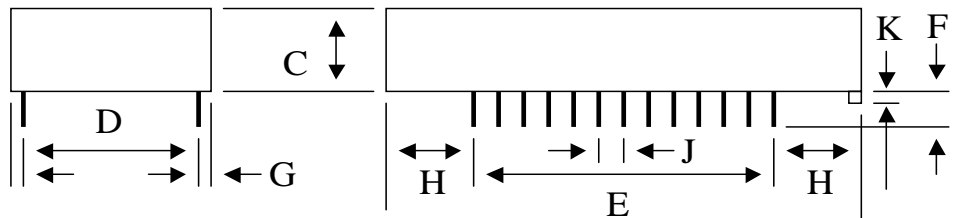
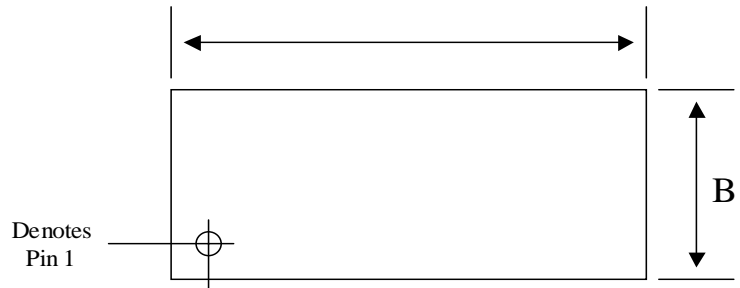

XE0068DT ABSOLUTE MAXIMUM RATINGS

Storage Temperature	-25° C to +85° C
Operating Temperature Range *	0° C to +70° C
Maximum Solder Temperature	220° C
Maximum Time Above Eutectic (183° C)	90 seconds
Preheat Dwell Time	120 to 180 seconds
* The XE0068DT can be ordered with an Operating Temperature of -40° C to +85° C at extra cost. Specify Model Number XE0068DT-ITR.	

XE0068DT Typical Connection Diagram

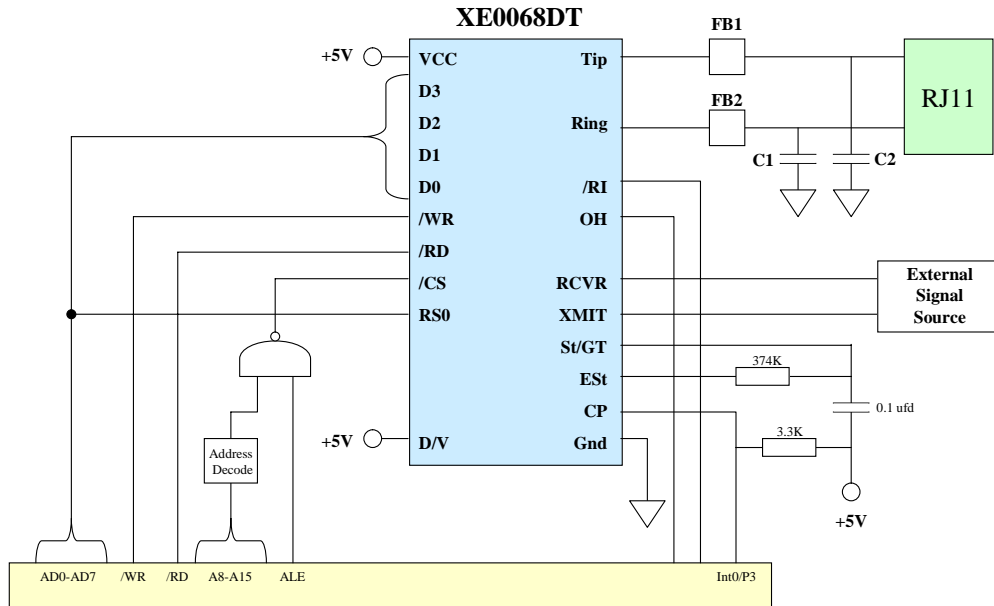

Recommended Parts

Designation	Description
C1, C2	470 picoFarad, 3000 Volts (Sprague part Number 30GA-T47)
FB1, FB2	Ferrite Beads (TDK part Number CB30-453215B)

XE0068DT Call Progress Detection Circuit

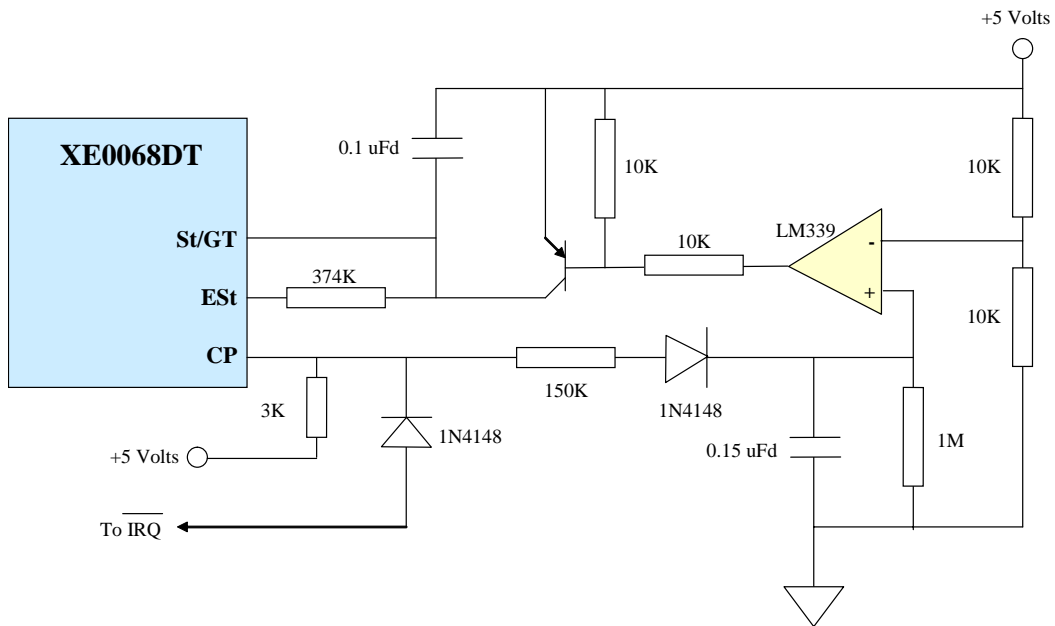

XE0068DT Pin Descriptions

PIN	NAME	I/O	DESCRIPTION
1	VCC	---	+5 Volts
2-5	D0-D3	I/O	These signals represent the 4-bit data bus which carries the DTMF information per the chart below.
6	/WR	I	Read and Write determine the direction of DTMF data. A low on /WR with /RD high allows the processor to write to the XE0068DT.
7	/RD	I	Read and Write determine the direction of DTMF data. A low on /RD with /WR high allows the processor to read from the XE0068DT.
8	/CS	I	A low on Chip Select, selects the XE0068 DTMF data bus.
9	RS0	I	This input selects the register to be used. A low selects the data register and a high selects the status or control registers.
13	D \bar{V}	I	A low on Voice/Data selects a transmit level of 0 dBm for voice or DTMF; a high sets a -9 dbm transmit level for data transfer.
14	GND	---	Ground
15	CP	O	In DTMF mode CP acts as an interrupt. CP goes low when a valid DTMF Tone is transmitted or received. In Call Progress Mode CP provides a square wave representation of the call progress signal on the phone line.
16	ESt	O	Goes high to indicate that a valid tone pair has been detected. A momentary loss of signal causes ESt to go low.
17	St/GT	I/O	As an input, St/GT latches the DTMF code into the Receive Data Register when the threshold voltage is reached. As an output, St/GT goes high to disable the guard timer after the threshold voltage is reached.
18	XMIT	I	Analog input signal to the line interface, input impedance on XMIT is typically 10 Kohms at 1800 Hz. Signals from -15 to +5 dBm will be placed on the line at -10dBm \pm 1 dBm.
19	RCVR	O	Analog output signal from the 2-4 wire converter, the output impedance of RCVR is typically 10 ohms at 1800 hz.
21	OH	I	Hookswitch control. A high closes the internal relay to connect the equipment to the phone line.
22	/RI	O	Ring Indicate, output, active low, TTL, indicates the modem is receiving a ring signal.
24	Ring	---	Ring connection to the phone line (RJ11 Pin 4).
26	Tip	---	Tip Connection to the phone line (RJ11 Pin 3)

XE0068DT Register Selection

Table 1 below shows the combination of RS0, /WR, and /RD to select each register.

Table 1	RS0	/WR	/RD	Function
	0	0	1	Write to Transmit Data Register
	0	1	0	Read from Receive Data Register
	1	0	1	Write to Control Register A or B
	1	1	0	Read from Status Register

DTMF Codes

Table 2 below shows the 4-bit codes applied to D0-D3 to represent each DTMF Digit.

Table 1	DTMF Digit	1	2	3	4	5	6	7	8	9	0	*	#	A	B	C	D
	D0	1	0	1	0	1	0	1	0	1	0	1	0	1	0	1	0
	D1	0	1	1	0	0	1	1	0	0	1	1	0	0	1	1	0
	D2	0	0	0	1	1	1	1	0	0	0	0	1	1	1	1	0
	D3	0	0	0	0	0	0	0	1	1	1	1	1	1	1	1	0

XE0068DT Status Register

Table 3 below defines the bit codess which can be read from the status register.

Table 3	Bit	Indicator	Status Set	Status Cleared
	0	IRQ	An interrupt has occurred	Interrupt inactive, Cleared after Status Register Read
	1	Transmit Data Register Empty	Transmitter Ready for New Data	Status has been read or is in non-burst mode
	2	Receive Data Register Full	Receive Data Register contains valid data	Status Register has been Read
	3	Delayed Steering	Set upon detection of the absence of a DTMF signal	Cleared upon detection of a valid DTMF signal

XE0068DT Control Register A

Table 4 below defines the XE0068DT operations set by the bits in Control Register A.

Table 4	Bit	Signal	Function
	0	TOUT	Tone Output Control: This bit controls the tone transmit functions. A high enables the tone output; a low turns tone output off.
	1	CP/ $\overline{\text{DTMF}}$	Call Progress or DTMF Mode: A logic high enables the XE0068DT to detect call progress tones. A low enables DTMF send and receive mode. In call progress mode a square wave representation of the incoming signal will be presented on the CP output, IRQ enabled. DTMF tones cannot be decoded in call progress mode.
	2	IRQ	Interrupt Enable: A logic high enables the interrupt function. When IRQ enabled and DTMF mode is selected, the CP output will go low when either a valid DTMF signal is received or the transmitter is ready for more data (burst mode).
	3	RSEL	Register Select. A logic high on bit 3 sets the XE0068DT to select Control Register B for the next write cycle. After writing to Control Register B, the next control register write cycle will be directed to Control Register A.

XE0068DT Control Register B

Table 5 below defines the XE0068DT operations set by the bits in Control Register B.

Table 4	Bit	Signal	Function
	0	$\overline{\text{Burst}}$	Burst Mode: A logic low enables burst mode. When Burst Mode is activated, DTMF tones can be transmitted by writing the correct code to the Transmit Register. The XE0068DT transmits a tone burst of 51 milliseconds on and 51 milliseconds off. In call progress mode the duration of the tone burst and pause after the tone burst are doubled to 102 milliseconds. When not in Burst Mode the XE0068DT transmits the tone as long as TOUT, Status Register A, is active.
	1	Test	Test Mode: A logic high enables the Test Mode in the XE0068DT. When the Test and DTMF modes are selected, the signal on CP reflects the state of the delayed steering bit of the status register.
	2	S/D	Single or Dual Tone Generation: A logic high sets the XE0068DT to generate a single tone rather than transmitting two tones.
	3	C/R	Column or Row: Control Register B bit 3 determines if the row or column tone is transmitted when single tone operation is selected. A logic high selects the row tone output

XE0068DT Operational Modes

Burst Mode Burst mode is used to transmit DTMF signals of specific duration. The XE0068DT transmitter sends symmetric tone bursts which are on for 51 milliseconds and off for 51 milliseconds. This is a standard interval for central office switching. When call progress mode is also selected extended bursts of 102 milliseconds can be sent.

Single Tone Generation The XE0068DT may be used to generate single tones as well as tone pairs. Control Register B regulates single tone transmission.

Call Progress Mode Call Progress Mode allows detection of the various tones used to identify the status of a call. They include Ring Back, Busy Tone Dial Tone, etc. In call Progress Mode the XE0068DT provides a square wave representation of these signals on the CP pin. The system host can decode the incoming call progress tones.

Initialization Procedure

Description	Control Lines			Data Bits			
	RS0	WR	RD	D3	D2	D1	D0
Read Status Register	1	1	0	X	X	X	X
Write to Control Register	1	0	1	0	0	0	0
Write to Control Register	1	0	1	0	0	0	0
Write to Control Register	1	0	1	1	0	0	0
Write to Control Register	1	0	1	0	0	0	0
Write to Control Register	1	0	1	0	0	0	0
Read Status Register	1	1	0	X	X	X	X

* Performs a software reset on the XE0068DT

Call Progress Tone Definitions

The chart below shows the signal characteristics for the most common call progress tones in the United States. Check the frequency and cadence on the CP line to identify signals in Call Progress mode.

Tone	Frequency (Hz)	Cadence	Level	Description
Dial Tone	350 + 400	Steady	-13 dBm	Indicates the network is ready to receive dialing signals
Ringback	440 + 480	2 sec. On 4 sec. Off	-19 dBm	Indicates the called line is ringing
Busy Tone	480 + 620	.5 sec. On .5 sec Off	-24 dBm	Indicates the called line has been reached but is currently in use.
Reorder	480 + 620	.25 sec. On .25 sec Off	-24 dBm	Indicates the switching path is busy
Partial Dial Tone	480	Steady	-17 dBm	Notifies the calling party that dialing has not begun in the allotted time or that not enough digits have been dialed.

XE0068DT Electrical Specifications ($V_{cc} = +5 \text{ Volts} \pm 5\%$, $T_a = 70 \text{ deg C.}$)

Parameter	Conditions	Min	Typ	Max	Units
Power Supply Current	Ring Indicate Active		20		mA
Coupler Match	Output impedance	531	536	541	ohms
AGC Input Range	Maintaining steady output level	-40		0	dBm
AGC Output Level	D \bar{V} held high	-20		-9	dBm
AGC Output Level	D \bar{V} held low	-11		0	dBm
Billing Delay	OH activated	2.0	2.3		seconds
Transhybrid Loss	at 1000 Hz		-34		dBm
Receive Loss	at 1000 Hz	-1.0	0	1.0	dB
Ring Detect Sensitivity	Min. AC voltage between Tip & Ring Type B ringer	38			v _{rms}
Ring Indicate Output Voltage	Ring Voltage present on Tip & Ring		0.2	0.5	volts
Loop Current Switch Control Voltage	ON: (off-hook)	2.0	3.0		volts
	OFF: (on-hook)		0.2	0.5	volts
Loop Current Switch Control Current	Off-hook		0.1	2.0	mA
Loop Current	Off-Hook current draw from Telephone Line	0	20	100	mA
Data Bus,	Low Level Input Voltage			0.8	volts
	High Level Input Voltage	2.0			volts
Receive Sensitivity	DTMF tones	-37			dBm
	Call Progress Tones	-30			dBm
Tone Duration to Detect				40	msec
Tone Frequencies	DTMF Transmission,		697 770 852 941 1209 1336		hz

XE0068DT Read/Write Clock Pulse Timing

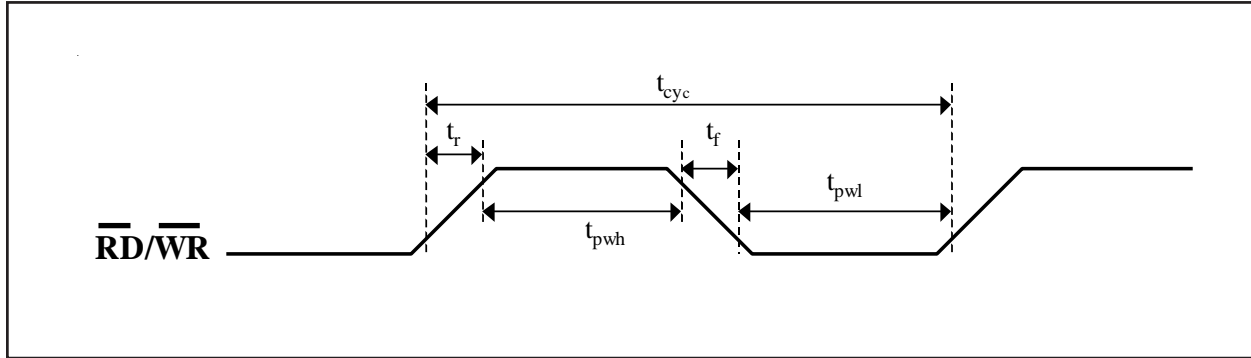

Signal	Definition	Min	Typ	Max	Units
t_r	Read/Write Rise Time			20	nanoseconds
t_f	Read/Write Fall Time			20	nanoseconds
t_{cyc}	Read/Write Cycle period		250		nanoseconds
t_{pwh}	Read/Write pulse width high		100		nanoseconds
t_{pwl}	Read/Write pulse width low	150			nanoseconds

XE0068DT Read Timing

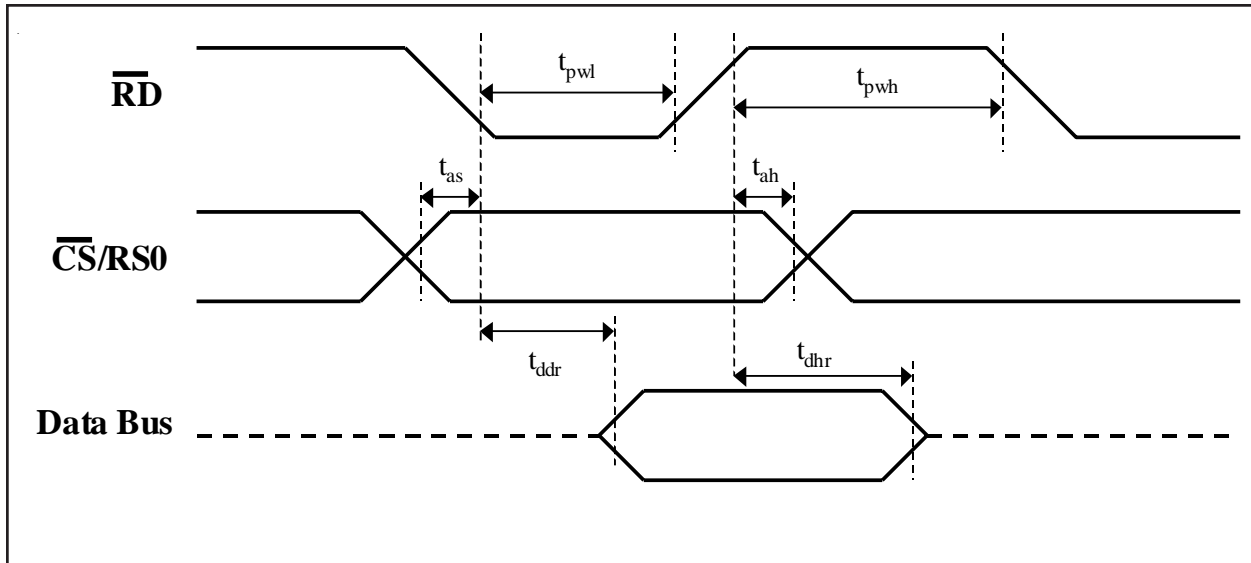

Signal	Definition	Min	Typ	Max	Units
t_{as}	Address Setup Time	23			nanoseconds
t_{ah}	Address Hold Time	26			nanoseconds
t_{pwl}	Read Pulse Width Low	150			nanoseconds
t_{pwh}	Read Pulse Width High		100		nanoseconds
t_{ddr}	Read to Valid Data			100	nanoseconds
t_{dhr}	Data Hold Time (Read)	22			nanoseconds

XE0068DT Write Timing

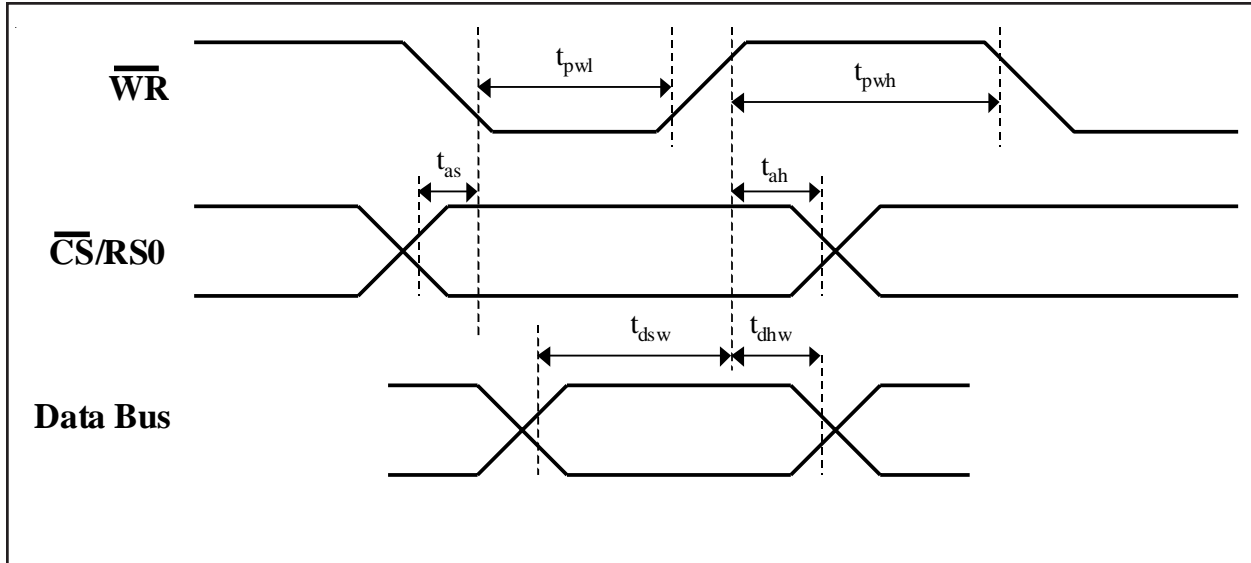

Signal	Definition	Min	Typ	Max	Units
t_{as}	Address Setup Time	23			nanoseconds
t_{ah}	Address Hold Time	26			nanoseconds
t_{pwl}	Write Pulse Width Low	150			nanoseconds
t_{pwh}	Write Pulse Width High		100		nanoseconds
t_{dsw}	Data Setup Time (Write)	45			nanoseconds
t_{dhw}	Data Hold Time (Write)	10			nanoseconds

FCC Information

This product complies with Part 68 of the FCC Rules and Regulations. With each device shipped, there is a label which contains, among other information, the FCC Registration Number and Ringer Equivalence Number (REN) for this product. You must, upon request, give this information to your telephone company.

Mounting this device in the final assembly must be made in such a manner as to preserve the high voltage protection between the TIP/RING connection and the rest of the system. Typically, this may be accomplished by maintaining a minimum spacing .100 mils between the TIP/RING trace to the RJ-11C Jack and low voltage portion of the system. No additional circuitry may be attached between TIP/RING and the telephone line connection unless specifically allowed in the rules.

The REN is useful to determine the quantity of devices you may connect to the telephone line and still have all of these devices ring when the number is called. In most, but not all areas, the sum of the RENs of all devices connected to one line should not exceed five (5.0). To be certain of the number of devices you may connect to the line, as determined by the REN, you should contact the local telephone company to determine the maximum REN for your calling area.

If your system causes harm to the telephone network, the telephone company may discontinue service temporarily. If possible, they will notify you in advance. If advance notification is not practical, you will be notified as soon as possible.

Your telephone company may make changes in its facilities, equipment, operations or procedures that could affect proper functioning of your equipment. If they do, you will be notified in advance to give you an opportunity to maintain uninterrupted service.

If you experience trouble with the device, please contact XECOM at (408) 945-6640 for information on obtaining service or repairs. The telephone company may ask you to disconnect this device from the network until the problem has been corrected or until you are sure that the device is not malfunctioning.

There are no repairs that can be made by the customer to the XE0068.

The device may not be used on coin service lines provided by the telephone company (this does not apply to private coin telephone applications which use standard telephone lines). Connection to party lines is subject to state tariffs.

FCC Registration Number	DWEUSA-75283-DP-W
Ringer Equivalence	0.5B
Telephone Jack	RJ11C

Terms of Sale

Devices sold by XECOM are covered by the warranty provisions appearing in its Terms of Sale only. XECOM makes no warranty, express, statutory, implied, or by description regarding the information set forth herein, or regarding the freedom of the described devices from patent infringement. XECOM makes no warranty of merchantability or fitness for any purposes. XECOM reserves the right to discontinue production and change specifications and prices at any time and without notice. This product is intended for use in normal commercial applications. Applications requiring extended temperature range, unusual environmental requirements, or high reliability applications, such as military, medical life-support or life-sustaining equipment, are specifically not recommended without additional processing and authorization by XECOM for such application.

Xecom assumes no responsibility for the use of any circuitry other than circuitry embodied in a Xecom

Life Support Policy

Xecom's products are not authorized for use as Critical Components in Life Support Devices or Systems.

Life Support Devices or Systems are devices or systems which, (a) are intended for surgical implant into the body, or (b) support or sustain life, and whose failure to perform, when properly used in accordance with instructions provided in the labeling, can be reasonably expected to result in significant injury to the user.

A Critical Component is any component of a life support device or system whose failure to perform can be reasonably expected to cause failure of the life support device or system, or to affect its safety or effectiveness.

Copyright, Xecom © 2002

While Xecom, Inc. has made every effort to ensure that the information presented here is accurate, Xecom will not be liable for any damages arising from errors or omission of fact. Xecom reserves the right to modify specifications and/or prices without notice. Product mentioned herein are used for identification purposes only and may be trademarks and/or registered trademarks of their respective companies.



Xecom Incorporated
374 Turquoise Street, Milpitas, CA 95035
Ph:408-945-6640 Fax:408-942-1346
Email: info@xecom.com