

CH1786A Family of Ultra Small 2400bps Modems

INTRODUCTION

The CH1786A represents the next generation of full function, FCC Part 68 approved 2400bps modems in the CH1786 Family. These modems provide a fast, easy and flexible way to integrate a modem into any OEM product while utilizing the minimum amount of PCB space (1.01"x 1.27"x 0.52"). The CH1786A family only requires two external interfaces: a ITU-T V.24 serial interface that can be routed directly to a UART, and a Tip and Ring interface which goes directly to an RJ-11 jack for the PSTN line connection. The CH1786A can be controlled with industry standard AT commands and, hence, is compatible with available industry communication software. DTE speed conversion allows commands and data to be sent at rates that differ from the modem connection speed. In most cases, the CH1786A can be used interchangeably with the CH1786. See Attachment I for equivalency comparisons and differences by product.

All CH1786A modems support asynchronous operation at 2400bps, 1200bps, and 300bps to both Bell and ITU-T standards. The CH1786A also supports Fast Connect and LAPM/MNP Error Correction.

The resident PSTN line interface, or Data Access Arrangement (DAA), while being FCC approved, is also Industry Canada CS-03 Part I Registered. Further, the CH1786A can be approved in other countries that require 1500VAC RMS isolation requirements per UL 1950 Edition 3.

The CH1786A family of modems operate off a single 5-volt supply. The low power operation and automatic standby mode make these modems ideally suited for portable equipment. In addition, their small physical size affords maximum flexibility in equipment design.

CH1786A comes with FCC Part 68 approval and is shipped from the factory with an FCC Part 68 label indicating the registration number and ringer equivalent. This label should be prominently displayed on the end product.

FEATURES

- Supports Standards ITU-T V.22bis, V.22, Bell 212, and Bell 103.
- FCC Part 68 approved:
US:B46MM07BCHXXXAYY
- Industry Canada CS-03 Part I Registered:
IC:176A-CHXXXAY

- AT Command structure with extensions.
- 1500 VAC RMS isolation barrier minimum, 2122V peak surge protection minimum.
- Error Correction.
- Fast Connect (V.22).
- Single 5 volt operation.
- Caller ID (optional).
- Low power operation with automatic reduced power standby mode.
- Zero Power (optional).
- Automatic adaptive and fixed compromise equalization.
- Size: 1.01"x 1.27"x 0.52" (nominal).
- NVRAM allows storage of custom configurations and telephone numbers.

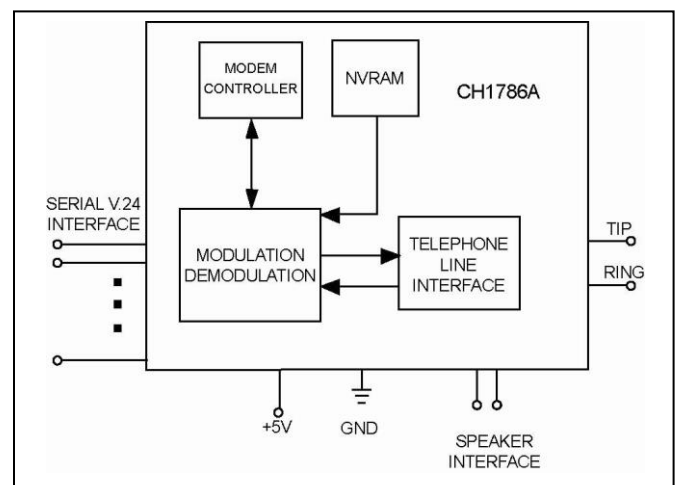

Figure 1. Functional Block Diagram of CH1786A.

DESCRIPTION OF FUNCTIONAL BLOCKS AND DISCUSSION OF BASIC OPERATIONS

Figure 1 contains a functional block drawing of the CH1786A. The CH1786A is a highly integrated, full-function modem, comprised of a modulator/demodulator, controller, NVRAM and an FCC Part 68 approved PSTN line interface.

Modulation/Demodulation and Modem Controller.

These functions are provided by a monolithic modem integrated circuit. This IC has built-in facilities to accommodate integrated AT command control and contains the necessary resident interfaces for general communication and routing to the DAA.

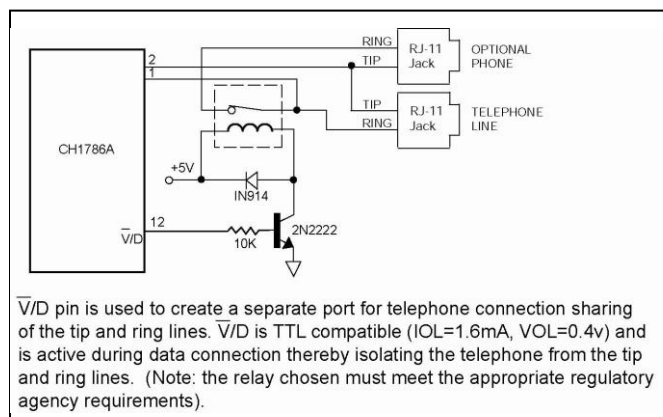

Figure 2. Voice/ Data Port Control

The CH1786A family of modems is designed to meet 1500VAC RMS isolation and provide 2122V peak surge protection. Consequently, the CH1786A satisfies U.S. FCC Part 68 and Industry Canada CS-03 Part I requirements, and will meet other international approval agency requirements that specify these levels of isolation.

With the exception of the U.S., most countries (including Canada) require submission of the final product or system containing the CH1786A to the appropriate governing regulatory agency for approval. Typically this is accomplished by submitting the final end product to an independent test house or consultant for evaluation. The test house or consultant then forwards the test results and applicable documents to the regulatory agency. Call Cermetek for a list of suggested consultants.

Non-Volatile RAM (NVRAM). The NVRAM present on the CH1786A is sufficient to store up to two user customized modem profile configurations. The **AT&Wn** command will store the active modem configuration in the selected NVRAM profile by specifying either an n of 0 or 1. The CH1786A is delivered with Factory Default setup parameter values pre-stored in NVRAM profile 0.

The **AT&Yn** command selects the modem configurations to be automatically recalled and made active upon a reset or power up. The **ATZn** command immediately recalls and activates a stored profile configuration. Refer to Tables 4, 5 and 6 for storable S-Registers and available commands.

The NVRAM can save up to four telephone numbers with up to 31 digits or modifiers in each telephone number. The **AT&Zn=s** command will store s, the telephone number dial string. The individual NVRAM telephone number storage locations are selected by specifying an n of 0, 1, 2, or 3. The **ATDTS=n** command will cause the modem to dial the stored telephone number in location n.

SUPPORT FEATURES

AT Command Set. A 50-character command line is supported. The command line starts with **AT** and may contain standard or enhanced commands. The commands are compatible with EIA Document TR302.2/88-08006.

Serial Host Interface. The serial interface is a V.24 (EIA-232) compatible interface. Ten Bits total: 1 start bit, 1 stop bit, and eight data bits which can be either eight bits with no parity or seven odd or even with parity. The start bit is LOW going. RXD and TXD data is non-inverted. See pin description in Table 2.

Speaker Interface. The SPK output reflects the receiver analog input and provides a signal that can be used to monitor call progress. The SPK signal can drive a 300 Ω load directly. Typically, the SPK signal is input into an audio power amplifier and the amplifier, in turn, drives the speaker coil. The speaker is activated with the **ATMn** command. The speaker volume is adjusted using the **ATLn** command, where n is 0, 1, 2, or 3. Increasing numbers correspond to higher volume. Figure 5 indicates one method of driving an external 8 Ω speaker.

Phone Control. Cermetek's CH1786A contains a pin called Voice or Data (\bar{V}/D). The \bar{V}/D pin toggles high when the modem goes off hook. This pin can be used to activate a relay which can switch a telephone on or off the Tip and Ring incoming PSTN lines. This feature allows any telephone associated with the CH1786A to be disconnected when a data call is in progress, thereby preventing the data from being disturbed by an inadvertent telephone pick-up. See Figure 2.

Speed and Parity Selection. Prior to call initiation, the host controller trains the modem to the host speed (2400, 1200 or 300bps) and parity (odd, even, mark, space, or none) via a host-initiated training sequence. This training also sets the speed of the data for originate calls. The CH1786A will automatically adjust to the originator's speed when answering calls.

The CH1786A matches the host's parity when it returns status messages to the host. During a data connection, however, the modem passes parity through without interpretation or alteration.

Sleep Mode. To minimize power consumption, the CH1786A includes a power down feature called Sleep Mode. When activated, the CH1786A will automatically enter Sleep Mode after 1 to 255 seconds of inactivity. The inactivity delay is selected using the **ATS24** command and defaults to 0 which will disable this feature. The CH1786A returns to normal operation when a ring signal is received or upon an input low signal on the TXD pin. A SLEEP output signal is available to control power to external devices.

In Figure 5, a FET controlled by the SLEEP signal turns off the external speaker amplifier when the CH1786A enters Sleep Mode. In Sleep Mode, power is reduced to about 1/3 of normal operating power.

Zero Power Mode. The “P” versions of the CH1786A Family supports Zero Power Mode operation. If an application calls for zero power during standby periods, this feature allows the power to the CH1786A to be switched off using external circuitry and then reapplied when the CH1786A’s RI pin becomes active. The CH1786A can thus be powered down to zero.

Referring to Figure 3, the controller activates the relay switch, supplying power (+5V) to the CH1786A. In this configuration, the ring signal is used to “wake up” the CH1786A when the CH1786A is in the zero power state.

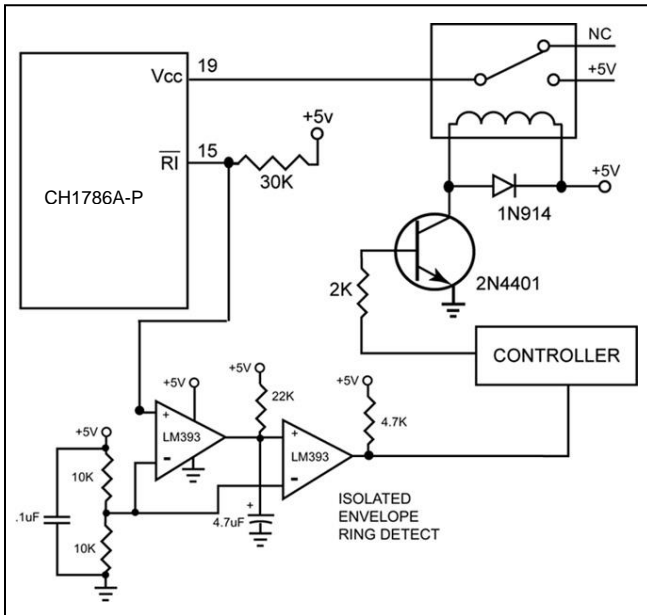

Figure 3. Zero Power Operation.

As indicated in Figure 2, the user connects an external pull-up resistor (Cermetek recommends 30k ohms) to an active 5V source thereby providing a small current to the CH1786A through the RI pin when the CH1786A is powered down (i.e., no power applied to the VCC pin). An internal blocking diode provides supply isolation.

The pins of the CH1786A will be in an undefined state when powered is switched off. This must be taken into consideration to assure that no unwanted signals are presented to the CH1786A during power down.

Guard Tone. A guard tone of 550 Hz or 1800 Hz can be generated at 6 dB or 9 dB below the transmit level, respectively, by using the **&Gn** command. For a more detailed discussion, refer to Cermetek Document 613-0001, “AT Commands and S-Registers”, which can be

found on the Cermetek web site located at <http://www.cermetek.com>.

Answer Tone. A ITU-T (2100 Hz) or Bell (2225Hz) answer tone is generated depending on the selected configuration. Refer to “AT Commands and S-Registers” for a more detailed discussion.

Data Encoding. The data encoding conforms to ITU-T recommendations V.22bis or V.22, or Bell212A, or 103, depending on the selected configuration. Refer to “AT Commands and S-Register” for a more detailed discussion.

Line Equalization. Transmitter and receiver digital filters compensate for delay and amplitude distortion during operation on nominal phone lines. In addition, automatic adaptive equalization in the receiver minimizes the effects of inter symbol interference.

Transmission Speed. In normal operation, the originating modem initiates the call and attempts to connect to the answering modem at a speed established by the originating modem’s controller prior to call initiation. This is referred to as the Initial Trained Rate. Upon receiving the call, the answering modem will attempt to connect to the originating modem at its Initial Trained Rate. If these two rates are identical, the connection is made. If the speeds differ, the answering modem must adjust its rate or terminate the call. Table 1 indicates the connection rate when the calling modem’s Initial Trained Rate and answering modem’s Trained Rate are different.

Error Correction. The CH1786A supports LAPM and MNP error correction. Error correction is enabled via the **\Nn** command. Enabling error correction overrides **&Qn** and sets S36 and S48 values. Refer to Cermetek, “AT Commands and S-Registers”, for a more detailed discussion.

Table 1. Connection Rates.

Answering Modem Initial Trained Rate	Connection Rate Resulting When Calling Modem Initial Rate Is:		
	300	1200	2400
300	300	1200	1200
1200	300	1200	1200
2400	300	1200	2400

NOTE

A 2400-baud connection rate will only result if both modems are initially set at 2400 baud.

Ring Indicator (RI). The RI pin follows the frequency of the ring signal and toggles low when the CH1786A detects an incoming call. The ring signal is typically 20 to 30 Hz and is on for 2 seconds and off for 4 seconds.

Although not TTL compliant, the RI pin can, nonetheless, be utilized to activate external circuitry including the external RST pin.

+MS Command. The user may override the automatic data rate function of the HS modems. This is accomplished by executing the **+MS** command. This command allows the user to specify the desired data modulation protocol. Further, the **+MS** command may be used to force a desired data rate and/or restrict the allowed data rate. The supported modulation schemes are listed above.

The following examples establish the V.22bis modulation scheme:

Enter: **AT+MS=V22B**
Result: **OK**

This is identical to the following explicit **+MS** command:

Enter: **AT+MS=V22B,0,300,1200,300,1200**
Result: **OK**

NOTE

The minimum transmission rate is not stored and will default to 300bps upon execution of reset or upon power up.

Refer to, "AT Commands and S-Registers", for a more detailed discussion of the **+MS** command.

Power Supply. The CH1786A modem module is a complex set of sub-systems. During the course of normal operation the CH1786A decodes analog signals from the telephone line that are in the millivolt range. Steps must be taken by the user to guarantee that power supply noise on all supply lines, including ground, does not exceed 50 mV peak to peak. Any frequency between 20 kHz and 150 kHz must be less than 500 micro volts peak. If necessary, use dedicated power and ground planes. Failure to provide such operating conditions could cause the CH1786A to malfunction or to function erratically.

The CH1786A requires a single +5V \pm 5% supply. It is recommended that by-pass capacitors be placed on the power supply as close to the modem's supply input as practical. It's recommended a 10 μ F Tantalum capacitor in parallel with a 0.01 μ F ceramic capacitor be used.

Voice/DTMF Tone Injection Port. The CH1786A provides two pins to allow the user to share the telephone line interface associated with the modem for voice and DTMF applications. Figure 4 contains a

schematic indicating one possible configuration for voice/ tone utilization.

Typically, voice communication would precede data communications. For this case, the following commands should be used to configure the CH1786A (Refer to Figure 4):

Enter: **ATS0=0<CR>** Disables auto-answer
Result: **OK**

Enter: **ATS7=255<CR>** Disables data-carrier time out
Result: **OK**

Enter: **ATS10=255<CR>** Disables lost-carrier time out
Result: **OK**

WARNING

The CH1786A has been FCC Part 68 and Industry Canada CS-03 Part I approved as a data modem only. Utilization of the Voice/DTMF Tone Port requires further registration. FCC and Industry Canada will require that the system, including the CH1786A and the handset or DTMF transceiver, adhere to Part 68 and CS-03 Part I rules.

The following command sequences illustrate implementation of common Voice/Tone Port applications.

- To answer a voice call.
 - Enter: **ATH1<CR>**
Result: **OK**
 - Drive V.INJ. HIGH to activate relay.
 - Begin voice conversation.
- To switch to data mode.
 - Drive V.INJ. LOW
 - At the originate modem:
Enter: **ATX1<CR>**
Result: **OK**
- To disconnect (hang-up) a voice call or a data call.
 - Enter: **ATH<CR>**
Result: **OK**
- Place a call to 1234567 using the CH1786A's DTMF tone generator, then use VOICE mode for voice communications. Note that the **CO** command disables carrier generation.
 - Enter: **ATDT1234567;C0<CR>**
Result: **OK**
 - Drive V.INJ. HIGH

MODEM CONTROL

The CH1786A modem may be controlled by sending serial ASCII command sequences. The commands

are sent to the modem serially on the TXD pin. After execution of a received command, the modem returns a serial status message that can be read on pin RXD. This message indicates command completion status. Refer to Table 3 for a complete list of status messages.

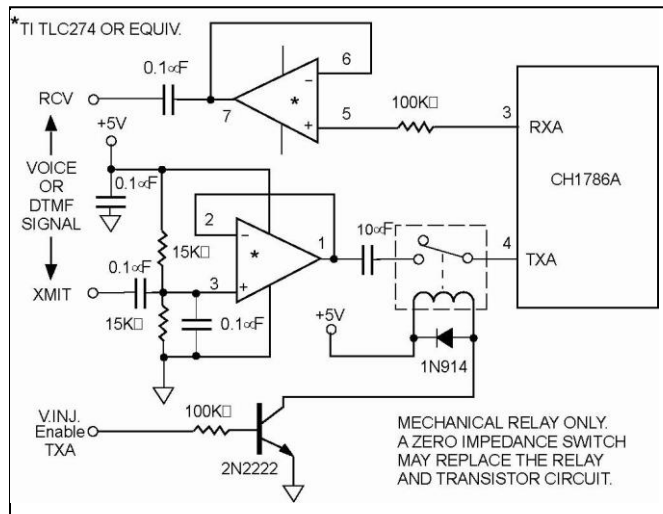

Figure 4. Voice/Tone Injection.

IMPORTANT NOTE

Although every effort has been made to design the CH1786A products to be fully and completely compatible with the existing CH1786 family, there are some minor differences. Refer to Table 14 for equivalency information and refer to Attachment I for a summary of product differences.

INITIALIZING THE MODEM

Before commands may be sent to the CH1786A, the CH1786A must be initialized. Initialization is a two step activity consisting of:

1. Hard Reset. This is accomplished by applying a hardware reset pulse to pin RST or by switching the power off and then back on.
2. Initial modem training. The CH1786A must be trained to the host's speed and parity (odd, even, mark, space or none).

These activities are briefly described below.

Reset. Upon applying power to the CH1786A, the CH1786A automatically generates an internal reset pulse. The user may also reset the modem externally by applying a high-going reset pulse to the RST pin for at least 10ms after the +5V power supply has stabilized. Delay sending commands to CH1786A for 200ms after reset has been initiated to allow the CH1786A time to properly reconfigure.

Training the Modem. Each modem must be trained to match its host's speed and parity so that it is able to recognize serial asynchronous commands sent to it by the host's UART. The host must retrain the modem each time a reset pulse is applied on RST or after a RESET serial command has been issued.

Modem Training Command Sequence. The CH1786A is trained by sending it the following sequence:

Enter: **AT<CR>**
 Result: **OK**
 Where: **A** and **T** may be either upper or lower case but must be the same case.
<CR> represents carriage return

The **AT** sequence is referred to as an attention sequence. The CH1786A will respond with one of the following status messages, depending on whether it is optioned for Terse (abbreviated) or Verbose (English) status messages.

Result: **0<CR>** (Terse)
 or
 Result: **<CR><LF>OK<CR><LF>** (Verbose)
 Where: **<CR>** represents carriage return (ASCII 13 or HEX 0D).
<LF> represents line feed (ASCII 10 or HEX 0A).

After responding with an OK, the CH1786A is in idle mode and is ready to accept additional commands. An alternate attention sequence **A/** may be sent which behaves much like the **AT** sequence except that it causes the previously entered command specified with an **AT** prefix to be executed. When given, both the **AT** and **A/** must be in upper case ASCII. No carriage return is needed for the **A/** command.

THE COMMAND FORMAT

Typical commands consist of three elements: the attention sequence, the commands themselves, and a terminating carriage return.

AT[commands]<CR>.
 Where: **AT** represents attention sequence.
[Commands] represents command strings.
<CR> represents carriage return (ASCII 13 or HEX 0D).

When entering commands to the modem, the backspace character-control-H (ASCII 8 or HEX 08) may be used to edit mistakes. **AT** and **A/** may not be edited. Multiple commands may be placed in the command line. A command line may be as long as 40 characters, excluding the letters **AT**. By way of example, the command below instructs the CH1786A

to configure itself to not echo characters when in command mode **E0** and then put itself in answer mode **A**.

Enter: **ATE0A<CR>**
Result: **OK**

AT Command Set. The available command set is divided into four types of commands: dial modifiers, basic commands, ampersand and percent commands. Refer to the complete list in Table 5.

AT Command Data Rate. With the serial interface, the rate is speed sensed for parity and format.

THE STATUS MESSAGES

The CH1786A responds with a status message after each command is executed. This status message may either be a numeric code (Terse Result Code) followed by a carriage return; or a carriage return and line feed with a message in English (Verbose Result Code) followed by a carriage return and line feed.

Various status code subsets are enabled with the Xn command. Where n=0, 1, 2, 3, 4 establishes the result codes allowed to be sent from the CH1786A to the DTE.

NOTE

The CH1786A is factory set to X4, which allows all result codes.

MODEM STATES

The CH1786A can be in either command mode or data mode. When the modem is idle, it is in command mode by default and will recognize commands. When data transmission is in progress, the CH1786A is in the data mode state and will not recognize commands. To force the CH1786A to recognize commands, the host must send an escape sequence to the CH1786A forcing it out of data mode and into command mode.

The escape sequence consists of a "guard time" (a period where no characters are sent to the modem), followed by 3 escape characters, followed by another guard time. The guard time is set by register S12. The escape character code is set in register S2. At power-up, the guard time is set to 1 second minimum, and the escape character is set as "+." There is no minimum delay between characters but the maximum delay is set by register S12.

The CH1786A will stay off-hook with its carrier on after the escape sequence is received. It will return an OK status message when it is ready to accept commands. The CH1786A may be put into data mode by issuing the command **ATO<CR>**.

AT COMMAND APPLICATIONS

Dialing A Phone Number. The Dial command takes the form **Dn**, where n is a string of characters. In the simplest form, n will be only the digits of the phone number to be dialed.

Example: Dial number.
Enter: **ATD1234567<CR>**
Result: **OK**

In response to this command, the CH1786A dials the telephone number "123-4567" and then waits for a carrier from the distant modem. If no carrier is detected within a given time (the default time is 30 seconds), the CH1786A automatically releases the line and sends a NO CARRIER result code. If a carrier is detected, the CH1786A gives a CONNECT result code and goes on-line, permitting communication with the distant modem.

The Dial Command may also be issued without a telephone number. ATD causes the modem to pick up the telephone line without dialing a number.

Pause During Dialing. When placing a call from an office with a telephone connected to a PBX, it may be necessary to dial an access code (usually the digit 9) to get an outside line. Inserting a comma in the telephone number instructs the modem to pause for a specific length of time. The factory set default pause time is 2 seconds.

Example: Dial 9,pause, dial number.
Enter: **ATDT9,1234567<CR>**
Result: **OK**

Multiple commas may be used to generate integer multiples of the specified delay time.

Originate a Call in Answer Mode. The D command forces the modem into originate mode. To call an originate-only modem, dial the number and set the modem to answer mode via the R command (reverse originate). This is done by including an R at the end of the telephone number.

Example: Change modem from original-only to answer mode.
Enter: **ATDT1234567R<CR>**
Result: **OK**

Multiple commas may be used to generate integer multiples of the specified delay time.

Redial Last Number. The repeat command is a convenient way to execute the previously entered command line.

Example: Use **A/**, the repeat command, to redial the last telephone number dialed.

Enter: **A/**
 Result: **ATDT1234567R<CR>** Previous command
OK line executed

Return to Command State. Use ; to return to command mode offer dialing.

Example: Touch-tone dial 9, pause, dial number, return to Command.

Enter: **ATDT9,1234567;<CR>**
 Result: **OK**

V.22 Fast Connect. The CH1786A supports non-standard V.22 fast connect protocols. This feature reduces the connect time to 3-4 seconds. However, to utilize the fast connect protocol, this protocol must be supported by both modems. Further, the DCE speed must be set to 1200 baud (i.e., V.22).

To setup the CH1786A to connect utilizing Fast Connect, execute the following commands:

Enter: **AT+MS=V22,0,300,1200,300,1200<CR>**
 Result: **OK**

Enter: **\$F2<CR>**
 Result: **OK**

This forces the CH1786A to communicate using the V.22 protocol and to attempt to connect using Fast Connect. If Fast Connect is not supported by the other modem, the CH1786A will connect using the standard V.22 protocol.

Caller ID (CID). The "C" versions of the CH1786A Family supports Caller ID. The **+VCID** command controls reporting and presentation of the data provided by the PSTN Caller ID services. Data is presented to the DTE between the first and the second ring indication. This command affects the data format for incoming calls as the call is being received.

Enter: **AT+VCID=n&W0&W1<CR>**
 Result: **OK<CR><LF>**

IMPORTANT NOTE

The **&W0** (or **&W1**) command, as appropriate per the specification of **&Y0** (or **&Y1**), must be executed before the **+VCID** command will be implemented by the CH1786A.

Where n is a decimal number corresponding to the selected option as described below.

- 0 Disable Caller ID reporting. (Default.)
- 1 Enables Caller ID with formatted presentation to the DTE. The data presented is in a <Parameter Description> <Value> pair format. The expected pairs are: date, time, name, and caller code

(telephone number). ASCII data is presented.

- 2 Enables Caller ID with unformatted presentation to the DTE. The data is presented in a continuous string. HEXADECIMAL data is presented.

Refer to Application Note # 174, Caller ID Feature For CH1786A, CH179XA and CH2056A Modems, for additional information and examples.

The **AT+VRID** command affects the format of the data provided by the PSTN Caller ID services for the last received call. The DTE is presented this data once every time the **+VRID** command is executed.

Enter: **AT+VRID=n<CR>**
 Result: **Data Stream from most recent call**

Where n is a decimal number corresponding to the selected option as described below.

- 0 Reports Caller ID with formatted presentation to the DTE. The data is presented the data items in a <Parameter Description> <Value> pair format. The expected pairs are: date, time, name, and caller code (telephone number).
- 1 Reports Caller ID with unformatted presentation to the DTE.

Refer to Application Note # 174, Caller ID Feature For CH1786A, CH179XA and CH2056A Modems, for additional information and examples.

IMPORTANT NOTE

Caller ID (CID) requires that the PSTN service provider supply the required data. The Caller ID feature will report the NULL string if the CID service is not activated by the PSTN service provider.

Automatic Answering. The S0 register controls the number of rings that must occur before the CH1786A answers a incoming call. The register may range in value from 0 to 255.

To set the CH1786A to not answer any incoming calls, executed the following command:

Enter: **ATS0=0<CR>**
 Response **OK**

When S0 is set to 0, the modem will not auto-answer. To set the CH1786A to answer after 3 rings, execute the following command:

Enter: **ATS0=3<CR>**
 Response **OK**

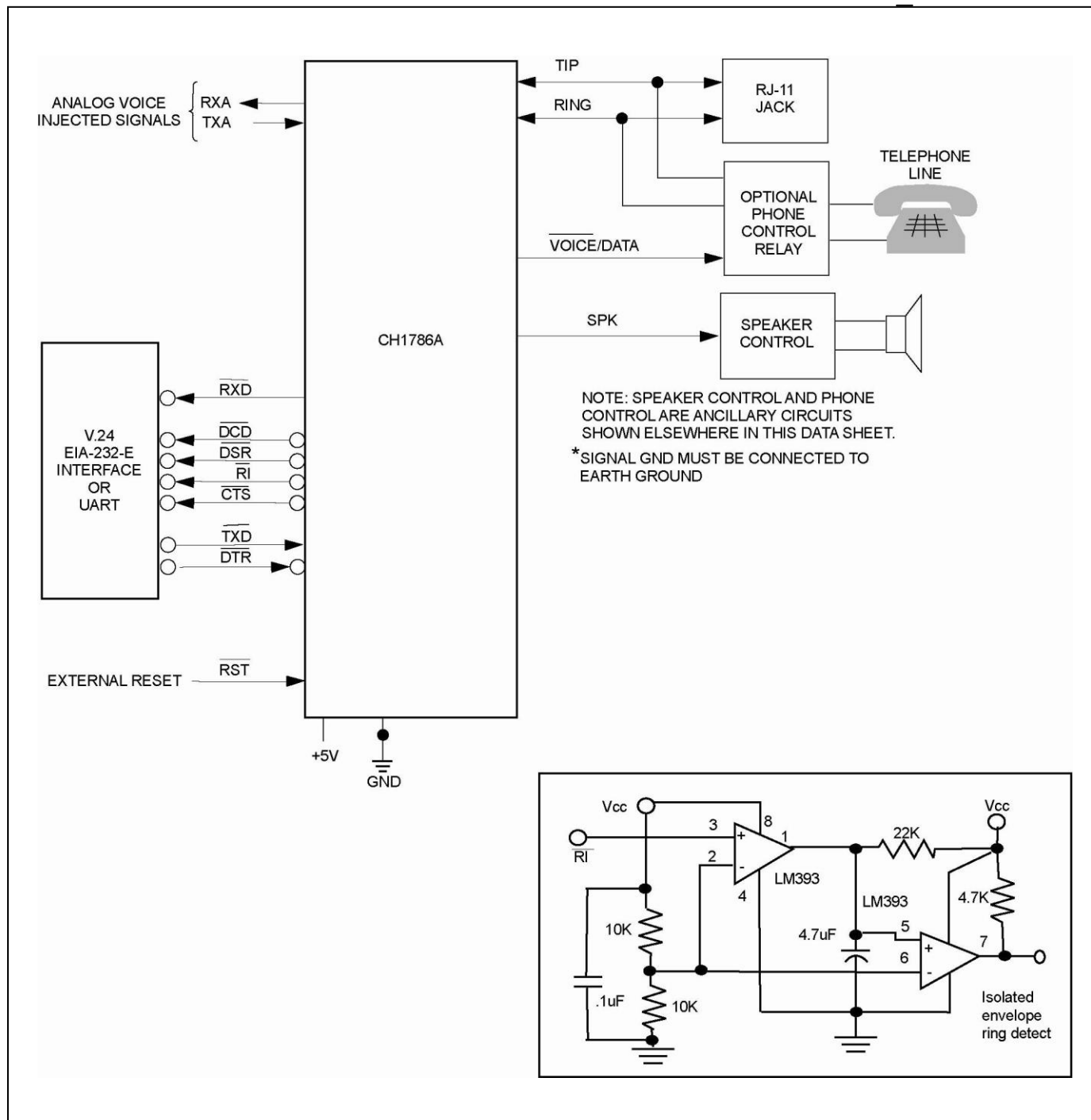

Figure 5. CH1786A block diagram illustrating typical feature implementations: V/D control, RJ-11 connection, speaker for call progress monitoring, serial port connection, external reset, +5V and GND.

Table 2. CH1786A Pin Descriptions

PIN	NAME	TYPE	FUNCTION
1	RING	I/O	RING. Directly connects to the telephone line's Ring lead through a user supplied RJ-11C jack.
2	TIP	I/O	TIP. Directly connects to the telephone line's Tip lead through a user supplied RJ-11C jack.
3	RXA	O	ANALOG VOICE INJECTED. Receive Signal. Let float if not used.
4	TXA	I	ANALOG VOICE INJECTED. Transmit Signal. Let float if not used
5	SPK	O	SPEAKER. Audio output for speaker. See speaker control schematic in Figure 5.
6	NC	-	No connection.
7	NC	-	No connection.
8	$\overline{\text{SLEEP}}$	O	SLEEP. Active LOW. A LOW indicates CH1786A is in low power idle mode. Used to control power to other devices. See Figure 5. Register S24 is the sleep timer register. When the CH1786A is inactive for a period of time specified by S24, the CH1786A will power down by about 1/3 of its normal operating power. During power down, all I/O lines become undefined. Default is (ATS24=0) disabled.
9	NC	-	No connection.
10	$\overline{\text{TXD}}$	I	TRANSMIT DATA. Active Low. Serial Transmit data input. Marking or a binary 1 condition is transmitted when a HIGH is asserted.
11	$\overline{\text{RXD}}$	O	RECEIVE DATA. Active Low. Serial Receive data output. Received marking or binary 1 condition is indicated by HIGH.
12	$\overline{\text{V/D}}$	O	VOICE/DATA. Used to switch between telephone and modem line use. In a typical application, V/D active HIGH opens the normally closed voice injection relay and disconnects the handset from the telephone line. HIGH indicates the CH1786A is off-hook and online. Therefore, this pin also reflects the state of the off-hook relay of the CH1786A. See Figure 2. Let float if not used.
13	$\overline{\text{DTR}}$	I	DATA TERMINAL READY. Active LOW. Switching off DTR can either return modem to command state, disconnect phone call, or reset modem. DTR should be set LOW when not used.
14	$\overline{\text{DSR}}$	O	DATA SET READY. Active LOW. LOW indicates handshaking with a remote modem is in progress, and/ or the data carrier of a remote modem has been detected.
15	$\overline{\text{RI}}$	O	RING INDICATION. This signal follows the frequency of the ringing signal and is normally about 20 to 40 Hz for 2 seconds on with 4 seconds off. This pin is also used for Zero Power option. See Figure 3.
16	$\overline{\text{CTS}}$	O	CLEAR-TO SEND. Active LOW. Used for hardware Flow Control of data.
17	$\overline{\text{DCD}}$	O	DATA CARRIER DETECT. Active LOW. LOW indicates a data carrier from a remote modem is detected. Must be enabled using the &C1 command.
18	NC	-	No Connection.
19	VCC	-	POWER SUPPLY. 5 volts \pm 5%
20	GND	-	GROUND. Note: Noise should be less than 50mV peak to peak.
21	RST	I	RESET. Active HIGH. This input must be asserted HIGH for at least 10 ms to reset the modem. RESET is then returned LOW for normal operation. If no system reset is available, let this pin float. Input impedance of driving circuit should be <10K.
22	NC	I	No Connection.

Table 3. S-Register Summary.

Register	Function	Range	Units	Saved	Firmware Defaults	Factory Defaults
S0	Rings to Auto-Answer	0-255	rings	*	000	001
S1	Ring Counter	0-255	rings		000	000
S2	Escape Character	0-255	ASCII	*	043	043
S3	Carriage Return Character	0-127	ASCII		013	013
S4	Line Feed Character	0-127	ASCII		010	010
S5	Backspace Character	0-255	ASCII		008	008
S6	Wait Time before Dial Tone or Blind Dialing	2-255	s	*	002	002
S7	Wait Time for Carrier, Silence or Dial Tone	1-255	s	*	050	050
S8	Pause Time for Dial Delay Modifier	2-255	s	*	002	002
S9	Carrier Detect Response Time	1-255	0.1s	*	006	006
S10	Carrier Loss Disconnect Delay	1-255	0.1s	*	014	014
S11	DTMF Tone Duration	50-255	0.001s	*	085	085
S12	Escape Prompt Delay	0-255	0.02s	*	050	050
S13	Reserved	-	-		000	000
S14	General Bit Mapped Options Status	-	-	*	146 (92H)	146 (92H)
S15	Reserved	-	-		000	000
S16	Test Mode Bit Mapped Options Status (&T)	-	-		000	000
S17	POS Option	-	-		000	000
S19	Reserved	-	-		000	000
S20	Reserved	-	-		000	000
S21	V.24/General Bit Mapped Options Status	-	-		052 (34H)	100 (74H)
S22	Speaker/Results Bit Mapped Options Status	-	-		117 (75H)	117 (75H)
S23	General Bit Mapped Options Status		-		000	000
S24	Sleep Inactivity Timer	0-255	s		000	000
S25	Delay to DTR off	0-255	0.01s		005	005
S26	RTS-to-CTS Delay	0-255	0.01s		001	001
S27	General Bit Mapped Options Status	-	-		073 (49H)	074 (4AH)
S28	General Bit Mapped Options Status	-	-		000	000
S29	Flash Dial Modifier	0-255	0.01s		070	070
S30	Disconnect Inactivity Timer	0-255	10ms		000	000
S31	General Bit Mapped Options Status	-	-		192 (C0H)	192 (C0H)
S36	LAPM Failure Control	-	-	*	007	007
S37	Line Connection Speed	-	-		000	000
S38	Delay Before Forced Hang-up	0-255	s		020	020
S39	Flow Control Bit Mapped Options Status	-	-		003	003
S40	General Bit Mapped Options Status	-	-	*	104 (68H)	104 (68H)
S41	General Bit Mapped Options Status	-	-	*	195 (C3H)	192 (C0H)
S43-S45	Reserved	-	-		-	-
S46	Data Compression Control	-	-	*	138	136
S48	V.42 Negotiation Control	-	-		007	007
S82	LAPM Break Control	-	-		000	000
S86	Call Failure Reason Code	0-26	-		021	021
S91	PSTN Transmit Attenuation Level	0-15	dBm		011	011
S92	FAX Transmit Attenuation Level	0-15	dBm		011	011
S95	Result Code Messages Control	-	-	*	000	000
S210	V.34 Symbol Rate	0-255	-		141 (8CH)	141 (8CH)

- NOTES:**
- Parameters indicated with a (*) in the Saved column may be stored in User Profile n=0, 1 by executing the appropriate &Wn command.
 - A stored Profile is a subset of allowed parameters and is comprised of those parameters displayed with the &V command.
 - Factory Default values that are different from the Firmware Default values are highlighted in **BOLD**.
 - Restore Factory Default values using Zn command.
 - Restore Firmware Default values using &Fn command

Table 4. Extended Result Code Summary.

Result Code Form		n is ATXn Command				
Terse or Short	Verbose or Long	0	1	2	3	4
+F4	+FCERROR	X	X	X	X	X
0	OK	X	X	X	X	X
1	CONNECT	X	X	X	X	X
2	RING	X	X	X	X	X
3	NO CARRIER	X	X	X	X	X
4	ERROR	X	X	X	X	X
5	CONNECT 1200	1	X	X	X	X
6	NO DIAL TONE	3	3	X	X	X
7	BUSY	3	3	3	X	X
8	NO ANSWER	X	X	X	X	X
9	CONNECT 0600	1	X	X	X	X
10	CONNECT 2400	1	X	X	X	X
11	CONNECT 4800	1	X	X	X	X
12	CONNECT 9600	1	X	X	X	X
13	CONNECT 7200	1	X	X	X	X
14	CONNECT 12000	1	X	X	X	X
15	CONNECT 14400	1	X	X	X	X
16	CONNECT 19200	1	X	X	X	X
17	CONNECT 38400	1	X	X	X	X
18	CONNECT 57600	1	X	X	X	X
19	CONNECT 115200	1	X	X	X	X
20	CONNECT 230400	X	X	X	X	X
22	CONNECT 75TX/1200RX	1	X	X	X	X
23	CONNECT 1200TX/75RX	1	X	X	X	X
24	DELAYED	4	4	4	4	X
25	MESSAGE-WAITING	X	X	X	X	X
32	BLACKLISTED	4	4	4	4	X
33	FAX	X	X	X	X	X
35	DATA	X	X	X	X	X
39	+MRR: 75	X	X	X	X	X
40	+MRR: 300	X	X	X	X	X
42	+MRR: 600	X	X	X	X	X
44	+MRR: 1200/75	X	X	X	X	X
45	+MRR: 75/1200	X	X	X	X	X
46	+MRR: 1200	X	X	X	X	X
47	+MRR: 2400	X	X	X	X	X
48	+MRR: 4800	X	X	X	X	X
49	+MRR: 7200	X	X	X	X	X
50	+MRR: 9600	X	X	X	X	X
51	+MRR: 12000	X	X	X	X	X
52	+MRR: 14400	X	X	X	X	X
66	+DR: ALT	X	X	X	X	X
67	+DR: V42B	X	X	X	X	X
68	+DR: V44	X	X	X	X	X
69	+DR: None	X	X	X	X	X
70	+ER: NONE	X	X	X	X	X
77	+ER: LAPM	X	X	X	X	X

Table 4. Extended Result Code Summary (Continuation).

Result Code Form		n is ATXn Command				
Terse or Short	Verbose or Long	0	1	2	3	4
80	+ER: ALT	X	X	X	X	X
81	+ER: ALT-CELLULAR	X	X	X	X	X
83	LINE IN USE	X	X	X	X	X
85	OFF-HOOK INTRUSION	X	X	X	X	X
86	LINE REVERSAL DETECTED	X	X	X	X	X
87	NO LINE	X	X	X	X	X
91	CONNECT 31200					
130	+ILRR	X	X	X	X	X
134	+MCR: B103	X	X	X	X	X
135	+MCR: B212	X	X	X	X	X
136	+MCR: V21	X	X	X	X	X
137	+MCR: V22	X	X	X	X	X
138	+MCR: V22B	X	X	X	X	X
139	+MCR: V23	X	X	X	X	X
139	+MCR: V23C	X	X	X	X	X
140	+MCR: V32	X	X	X	X	X
141	+MCR: V32B	X	X	X	X	X
210	+MRR: 25333	X	X	X	X	X
211	+MRR: 26667	X	X	X	X	X
212	+MRR: 25333	X	X	X	X	X
213	+MRR: 22666	X	X	X	X	X
214	DIGITAL LINE DETECTED	X	X	X	X	X

IMPORTANT NOTE

An "X" in a column indicates that the message (either the long form if verbose, or the value only for short form) will be generated when that particular value of "n" (shown at the top of the column) has been selected by the use of **ATXn**. A numeral indicates which less explicit message (verbose or short form) will be output for that X option.

The Serial Interface Lines. The CH1786A supports a full EIA-232E/V.24 serial interface. Signal levels are TTL rather than EIA-232E level compatible, which allows direct connection of the CH1786A to the host UART without the need for level translation circuitry. See Table 2 for a complete pin description. The CH1786A is controlled by sending it serial commands over TXD and it's status determined by monitoring the serial status messages returned on

RXD. DTR is optionally used to reset, terminate calls or return CH1786A to command mode.

All other serial interface lines may be utilized for the convenience of a particular application but are not

Table 5. AT Command Summary.

Command	Function
A/	Re-execute command
A	Go off-hook and attempt to answer call
B0	Select CCITT connection at 300 or 1200bps
B1	Sect Bell connection at 300 or 1200bps
Dn	Dial modifier where n is one or more of the following: P Pulse Dial T Touch Tone Dial W Wait for Dial Tone ; Return to Command State @ Wait for Quiet Answer Command ! Flash Hook , Pause 0-9/ABCD Dial Digits/Characters & wait for credit card dial tone ^ Toggles calling tone L Redial last number *,# Star digit – tone dialing S=n Dial the number and store in Directory, n= 0 to 3
E0	Disable command echo
E1	Enable command echo
H, H0	Initiate a hang-up sequence
H1	If on-hook, go off-hook and enter command mode
L0	Set low speaker volume
L1	Set low speaker volume
L2	Set medium speaker volume
L3	Set high speaker volume
M0	Speaker off
M1	Speaker on during hand shaking and speaker off while receiving carrier
M2	Speaker on during hand shaking and while receiving carrier
M3	Speaker off during dialing and receiving carrier and speaker on during answering
O0	Go on-line
O1	Go on-line and initiate a retrain sequence
Sn	Select S Register n
Sn=m	Write value m to S Register n
Sn?	Read the value of S Register n
?	Returns Last addressed S Register value
V0	Short Form Result Code Option
V1	Long Form Result Code Option
X1, X2, X3, X4	Result Code Reporting Options
+++	Escape Code Sequence
Z0, Z1	The modem performs soft reset. Restore stored profile 0 or 1 after reset
&C0	Force DCD active regardless of the carrier state
&C1	DCD to follow the carrier state

Table 5. AT Command Summary (Continuation).

Command	Function
&D0	Modem ignores DTR
&D1	Modem assumes command state
&D2	Modem hangs up, assumes command state and disables auto-answer
&D3	Modem assumes initialization state
&F0	Restore Factory configuration 0
&F1	Restore Factory configuration 1
&G0, 1, 2	Guard Tone Options
&K0	Disable DTE/DCE flow control
&K1,2	Not Supported
&K3	Enable RTS/CTS DTE/DCE flow control
&K4	Enable XON/XOFF DTE/DCE flow control
&K5	Enable transparent XON/XOFF flow control
&P0, 1, 2, 3	Make to Break Ratio Options
&Q0	Select direct asynchronous mode
&Q1,2,3,4	Not Supported
&Q5	Modem negotiates an error corrected link
&R0	CTS tracks RTS
&R1	CTS always on
&S0	DSR always on
&S1	DSR active after answer tone detected and inactive after loss of carrier
&T0	Terminate Loopback Test
&T1	Initiate Loopback Test
\Bn	Send break of n x 100 msec (n=0 to 9)
\N0	Select normal speed buffered mode
\N1	Select direct mode
\N2	Select reliable mode
\N3	Select auto reliable mode
\N4	Force LAPM mode
\N5	Force MNP mode
\V0	Connect messages are controlled by the command settings X, W, and S95
\V1	Connect messages are displayed in the single line format
MODULATION COMMANDS	
+MS	Select modulation
+MCR=n	Carrier protocol n reporting
+MR=n	Select extended Modulation Reporting of +MCR and +MRR to DTE
+MRR=m, n	Report Transmit m and Receive n DCE rates to DTE
CALLER ID COMMANDS	
+VCID	Select data presentation format n (0-2) for incoming calls.

Table 5. AT Command Summary (Continuation).

Command	Function
+VRID	Select data presentation format n (0-1) for most recently received incoming call.

ERROR CORRECTING COMMANDS

%C0	Disable data compression
%C1	Enable MNP 5 data compression
%C2	Enable V.42bis data compression
%C3	Enable both V.42bis and MNP 5 compression

STORED PROFILE COMMANDS

&V	Display current configuration
&W0	Store the active profile in NVRAM profile 0
&W1	Store the active profile in NVRAM profile 1
&Y0	Recall stored profile 0 upon power up
&Y1	Recall stored profile 1 upon power up
&Zn=x	Store dial string x (31 digits max) to location n (0-3)

MNP10 COMMANDS

-K0	Disable MNP 10 extended services
-K1	Disable MNP 10 extended services
-K2	Disable MNP 10 extended services

FAX COMMANDS

+FCLASS=n	Service Class
+F<cmd>?	Report active configuration for specified command cmd
+F<cmd>=?	Report capabilities for specified command cmd
+FAA=n	Data/Fax Auto Answer
+FLO	Flow Control
+FMI?	Report Manufacturer ID
+FMM?	Report Model ID
+FMR?	Report Revisions ID
+FRM=n	Receive Data with n protocol
+FTM=n	Transmit Data with n protocol
+FRH=n	Receive Data with HDLC Framing with n protocol
+FTH=n	Transmit Data with HDLC Framing with n protocol
+FTS=n	Stop Transmission and Wait

FAST CONNECT COMMANDS

\$F0	Normal connection (Default)
\$F1,3,4	Not Supported
\$F2	V.22 Fast Connect

IDENTIFICATION COMMANDS

I0	Reports product code
I3	Reports firmware Identification code

required by the CH1786A depending on user's initialization string. Unused outputs (from modem) should be left unconnected. Unused inputs should be set to the proper logic level. See Table 2.

Fax Modes. The CH1786A Product Family supports Send and Receive FAX. The modes and rates are determined by the **AT+F** commands. Refer to Table 6A.

FAX modem processing is explicitly defined in ITU-TV.29, ITU-TV.27, ITU-TV.21 and ITU-T V.17 recommendations. All modulation, wave-form spectrum, and data processing functions conform to the appropriate specifications.

PHONE LINE CONNECTION GUIDELINES

1. The CH1786A must be mounted in the final assembly such that it is isolated from exposure to any hazardous voltages within the assembly. Adequate separation and restraint of cables and cords must be provided.
2. The circuitry from the CH1786A to the telephone line interface must be provided in wiring that carries no other circuitry other than that specifically allowed in the FCC rules (such as A and A1 leads).
3. Connection to phone line should be made through an RJ-11C jack.
4. PCB traces from the modem's RING and TIP pins to the RJ-11C jack must be 0.1 inch spacing or greater to one another and 0.2 inch spacing or greater to all other traces. The traces should have a nominal width of 0.020 inches or greater.
5. The RING and TIP PCB traces should be as short as possible and oriented to prevent coupling other high speed or high frequency signals present on the host circuit PCB.
6. No additional circuitry other than that shown in Figure 6 may be connected between the modem module and the RJ-11C jack. Doing so will invalidate the FCC approval.
7. Surge protection is provided internally. (See Figure 6). This is mandatory to maintain FCC Part 68 conveyed approval.
8. The CH1786A, the RJ-11C jack, the interfacing circuitry and all PCB traces in between, must be contained on a PCB with a 94 V-0 flammability rating.
9. The supplied FCC registration label must be applied visibly on the outside of the product.
10. The product's User Manual must provide the user with instructions for connection and use as recommended in the FCC Registration Section below.

CH1786A HANDLING AND ASSEMBLY RECOMMENDATIONS

The CH1786A contains static-sensitive components and should only be handled by personnel and in areas that are properly protected against static discharge. The two recommended mounting techniques for physically connecting the CH1786A to a PCB are discussed below.

Direct Soldering. The CH1786A may be wave soldered. All CH1786A products are hermetically sealed and will not be harmed by industry standard wave soldering processes.

Socketing. The socketing approach to mounting eliminates cleaning and desoldering concerns. When the socket is used, it must make a solid connection to all pins. Failure to do so will cause unreliable or intermittent operation. Also, steps should be taken to assure that the module remains tightly seated in the socket during shipping. Cermetek recommends using sockets from Samtec. See Application Note # 130, Summary of Recommended Suppliers.

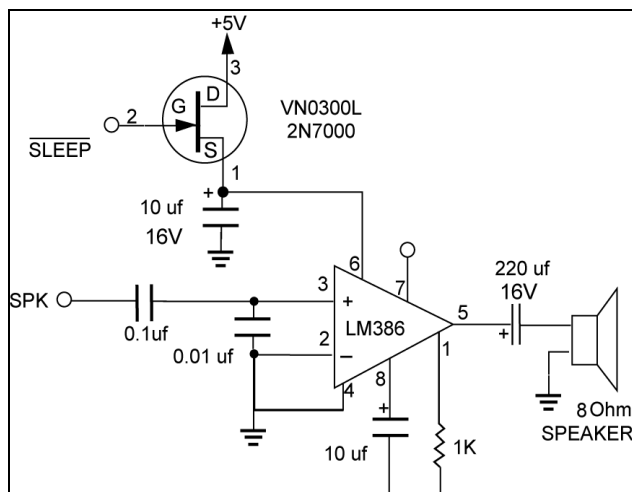

Figure 5. Speaker Control Circuit: Optional to allow for call progress monitoring.

FCC REGISTRATION

All products in the CH1786A family are registered with the FCC (Federal Communications Commission) under Part 68. To maintain the validity of the registration, you must serve notice to the end user of the products of several restrictions the FCC places on the modem and its use.

In addition to restriction notification, the FCC requires that Cermetek make all repairs to all products in the CH1786A family. If repairs are necessary after installation of the CH1786A in the end product and the end product has been delivered to the end user, the end product must be returned to the end product supplier where the CH1786A can be removed and then forward to Cermetek for repair. The following

notice is recommended and should be included in the end product's user manual.

FOR YOUR USER'S MANUAL

The FCC Part 68 rules require the following (or equivalent) be provided to the end user of equipment containing a DAA.

Type of Service. The (insert end product name) is designed to be used on standard device telephone lines. It connects to the telephone line by means of a standard jack called the USOC RJ-11C (or USOC RJ45S). Connection to telephone-company-provided coin service (central office implemented systems) is prohibited. Connection to party lines service is subject to state tariffs.

Changes in Attestation Procedure for Plugs and Jacks. (Name of applicant) attests that the network interface plugs or jacks used on this equipment comply with and will continue to comply with the mechanical requirements specified in Part 68, sub-part F, specifically the dimensions, tolerances and metallic plating requirements. The compliance of these connectors will be assured by purchase specifications and incoming inspection. Documentation of such specifications and/ or inspections will be provided to the FCC within 30 days of their request for the same.

Telephone Company Procedures. The goal of the telephone company is to provide you with the best service it can. In order to do this, it may occasionally be necessary for them to make changes in their equipment, operations or procedures. If these changes might affect your service or the operation of your equipment, the telephone company will give you notice, in writing, to allow you to make any changes necessary to maintain uninterrupted service.

In certain circumstances, it may be necessary for the telephone company to request information from you concerning the equipment which you have connected to your telephone line. Upon request of the telephone company, provide the FCC registration number and the ringer equivalence number (REN); both of these items are listed on the equipment label. The sum of all of the REN's on your telephone lines should be less than five in order to assure proper service from the telephone company. In some cases, a sum of five may not be useable on given line. Consult your telephone provider.

If Problems Arise. If any of your telephone equipment is not operating properly, you should immediately remove it from your telephone line, as it may cause harm to the telephone network. If the telephone company notes a problem, they may temporarily discontinue service. When practical, they will notify you in advance of this disconnection. If

advance notice is not feasible, you will be notified as soon as possible.

When you are notified, you will be given the opportunity to correct the problem and informed of your right to file a complaint with the FCC. Contact your local telephone service provider if you have any questions about your phone line.

In the event repairs are ever needed on the (insert your product name), they should be performed by (insert your company name) or an authorized representative of (insert your company name). For information contact: (insert your company address).

DEFAULT STATUS, PERFORMANCE, AND SPECIFICATIONS

Factory Defaults. The following is a summary of the Default Configuration Profile installed by Cermetek Microelectronics, Incorporated, prior to delivery of the CH1786A.

Async mode selected
 2400bps
 Even parity
 Auto answer enabled
 Command echo ON
 Error correction OFF
 All result codes enabled –extended
 Wait for dial tone before dialing =2 seconds
 Detects busy signal
 Full word result codes
 Pulse dial make/break ratio =39/61
 DSR enabled
 Modem enabled DTR
 DCD enabled
 Speaker enabled but off when receiving carrier
 Speaker volume set to low
 Guard tones disabled

Minimum DTR pulse width =0.1 seconds
 Ring count =01
 Escape code character =43
 Carriage return character =13
 Line feed character =10
 Back space character =08
 Duration of wait for dial tone =02 seconds
 Duration of wait for carrier after dialing =30 seconds
 Duration of dial pulse (comma)=02 seconds
 Carrier detect response time =0.1 seconds
 Escape code guard time =1 second
 Length of use after comma =2.0 seconds
 Last carrier to hang up delay =0.1 seconds
 DTMF interdigit delay =0.1 seconds
 Sleep mode inactivity time = off
 Long space disconnect disabled
 V.22B selected

Factory Pre-Configuration. Cermetek pre-configures the CH1786A modems with the following command set:

Enter: **AT+MS=V22B,1,300,2400,300,2400<CR>**
 Result: **OK**

Enter:
ATS0=1%C0&C1&D0&S1&Q6!N0&Y0&W0<CR>
 Result: **OK**

IMPORTANT NOTE

If the **AT&F**, **AT&F0** or **AT&F1** commands are executed by the user, the Factory Pre-configuration commands specified above must be executed after the **AT&F**, **AT&F0** or **AT&F1** commands to ensure proper configuration setup of the CH1786A

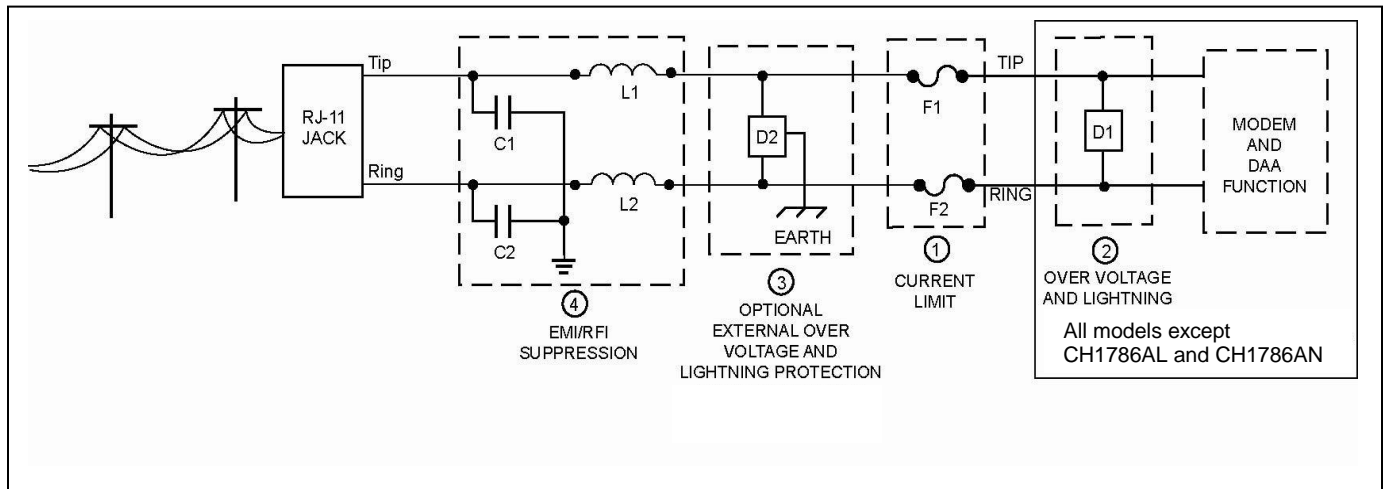

Figure 6. PSTN Line Interface for all CH1786A Products. CH1786AL and CH1786AN models do NOT contain internal Surge Protection (Dashed Box 2). The purchaser MUST provide external surge protection to maintain conveyed FCC Part 68 approval.

1. Current Limiting PSTN Protection Line Device.

Current limiting devices are mandatory to meet UL safety standards. To maintain conveyed FCC Part 68 approval, the current limiting components identified as F1 and F2 in dashed Box 1 must also survive FCC Part 68 surge testing. Refer to Cermetek Application Note #126, [Supplemental PSTN Line Protection](#), for more details. Refer to Application Note # 130, [Summary of Recommend Suppliers](#), for a list of suppliers and associated part numbers.

A resettable/repairable fuse (rated at 0.15 amps) is preferred because it resets automatically upon removal of the current flow. Non-resettable devices are also acceptable. Although CS-03 Part 1 (Canada) follows the requirements of FCC Part 68 (USA), Cermetek recommends contacting a certified independent lab to verify compliance in the specific application.

2. Over Voltage and Lightning Protection.

Surge Protection is provided by internal circuitry contained within all CH1786A models except CH1786AL and CH1786AN. No additional external components are required to maintain conveyed FCC Part 68 approval for all models EXCEPT CH1786AL and CH1786AN.

For CH1786AL and CH1786AN, the required surge protection (identified as D1 in Dashed Box 2) must be supplied externally. The purchaser must include some form of surge protection as described herein to maintain conveyed FCC Part 68 approval. Refer to Application Note # 130 for a list of suppliers.

3. Optional External Over Voltage and Lightning Protection.

In most environments, the internal two terminal surge suppressor (see dashed Box 3) is adequate.

For severe environments, use an external three terminal device with an earth ground as is shown in dashed Box 3.

4. EMI/RFI Suppression.

Suppression of emitted EMI/RFI is recommended and is typically required to obtain FCC part 15 A and/or B approval. EMI/RFI suppression circuitry is also used to suppress reception of externally generated EMI/RFI signals, such as strong radio signals, should the CH1786A be located near a source of such signals. Although no external EMI/RFI noise suppression circuitry is required to maintain conveyed FCC Part 68 approval, additional suppression may be added as described below without adversely affecting FCC Part 68 approval.

- A. To provide adequate EMI/RFI suppression, the capacitor/inductor network contained in dashed Box 5 should be located as close to the RJ-11C Jack as possible. Further, this network should be provided with an excellent ground path to the chassis.
- B. Capacitors C1 and C2 should not exceed 0.005 μ f. They must have a rating of 1.5KV and typically are 0.001 μ f \pm 20%. Inductors L1 and L2 may be either individual inductors or a dual inductor. Refer to Application Note #130 for a list of suppliers. For UL applications, choose capacitors and inductors that are UL 1950 Edition 3 listed. The actual values of the components used may vary depending on the end product design and the nature of the EMI/RFI. Consult an FCC Part 15 consultant, if required.

Table 7. CH1786A System Data Mode Compatibility Specifications.

Parameter	Specification	Parameter	Specification
Asynchronous	2400, 1200 600 bps character asynchronous. 0-300 bps asynchronous	Receive Carrier Frequencies V.22 bis, V.22, 212A	Originate 2400Hz \pm 7Hz Answer 1200Hz \pm 7Hz
Asynchronous Speed Range	TXD may differ +1%, -2.5% from modem output. Offsets will be corrected by adding/deleting stop bits.	Bell 103	Answer 'space' 2020Hz \pm 7Hz Answer 'mark' 2225Hz \pm 7Hz Originate 'space' 1070Hz \pm 7Hz Originate 'mark' 1270Hz \pm 7Hz
Asynchronous Format	8,9,10 bits, including start, stop, parity.	Receiver Sensitivity	OFF to ON threshold -43 dBm ON to OFF threshold -48 dBm
Telephone Line Interface	Two-wire full duplex over public switched network. On-chip hybrid and billing delay timers.	Billing Delay	2.0 to 3.0 seconds ($T_a=25^\circ\text{C}$)
Modulation	V.22 bis, 16 point QAM at 600 baud. V.22 and 212A, 4 point DPSK at 600 baud. 103 Binary phase coherent FSK.	Hysteresis	2 dB minimum
Self Test Pattern Generator	Alternate 'ones' and 'zeros' and error detector, to be used along with most loopbacks. A number indicating the bit errors detected is sent to DTE.	Line Equalization	Fixed compromise equalization, transmit. Adaptive equalizer for PSK/QAM, receive.
Transmit Carrier Frequencies V.22 bis, V.22, 212A	Originate 1200Hz \pm .01% Answer 2400Hz \pm .01%	Diagnostic Available	Local analog loopback. &T1 Local analog loopback. Must be used with error correction off (AT&Q6).
Bell 103	Originate 'space' 1070Hz \pm .01% Originate 'mark' 1270Hz \pm .01% Answer 'space' 2025Hz \pm .01% Answer 'mark' 2225Hz \pm .01%	Call Progress Tones Detected Computer Interface	With speaker or quiet screen messages (No dial tone, busy, ring, modem answer tone and voice). IBX PC/XT/AT bus compatible with an 8250/16450/16550A UART as a serial controller.

Table 8. CH1786A Electrical Specifications.

Parameter	Description	Min.	Typ.	Max.	Units
V _{CC}	Positive Supply Voltage- Noise less than 50mV	4.75	5.0	5.25	V
I _{CC} Off Hook	Nominal Operating Current when modem is OFF Hook		61	67	mA
I _{CC} On Hook	Nominal Operating Current when modem is ON Hook		58	64	mA
I _{CCPD}	Power Down Current @ V _{CC} = 5.5V when modem is in Power Down Mode ²		0.0		mA
I _{RIPD}	Current Supplied into RI pin when in Power Down Mode @ V _{CC} = 5.5V ²		11.0		uA
V _{IH}	High Level Input Voltage ¹	2		V _{CC} + 5	V
V _{IL}	Low Level Input Voltage ¹	0		0.8	V
I _{IN}	Input Leakage Current (TXD, DTR, RTS)	-10		+10	uA
I _{LO}	Leakage Current DCD, HS, RXD, SLEEP, DSR	-10		+10	uA
VT+	Positive Hysteresis Threshold for RESET pin			3.0	V
VT-	Negative Hysteresis Threshold for RESET pin	1.33			V
V _{OH}	High Level Output Voltage (I _{OH} = 2.0mA) ¹	2.4			V
V _{OL}	Low Level (I _{OL} = - 2.0mA) ¹			0.4	V

Test conditions: VCC = 5V ± 10%, Temp = 0°C to 70°F (unless otherwise stated).

Notes:

1. Output Load = 50 pF ± one TTL.
2. With recommended 30k ohm external resistor. Maximum external resistor range: 10k to 100k ohm.

Table 9. CH1786A Electrical Specifications.

Parameter	Minimum	Typical	Maximum	Units	Comments
DC Off Hook Impedance	125		312	Ohms	@16 to 80 ma
Trans Hybrid Loss		25		dB	600 Ohm, RXA, TXA
Ring Voltage Detect	25VAC		35VAC	V _{RMS}	Typically riding on 48VDC
Line Loop Current- (Off-Hook)	16		80	mA	
Return Loss @ 1000Hz		15		dB	600 Ohm
Ring Detect Frequencies	14	20	35	Hz	
Receiver Insertion Gain	-0.5	0.0	+0.5	dBm	600 Ohm- Data Mode
Transmit Power (Adjustable with S91)	-17.2	-13.0	-9.5	dBm	Into 600 Ohm Load
First Character After Reset	0.5	1.0	5	sec	Delay
Inter Character Delay	20	50		msec	Between all command characters
Command Delay	100	200		msec	Between all AT commands
Maximum Reset Drive	0		10K	Ohms	
Minimum Reset Pulse Duration	10			msec	If user supplied

Table 10. Other Performance Specifications.

Parameter	Minimum	Typical	Maximum	Units	Comments
DTMF total power	-5.3	-5.6	--5.8	dBm	Into 600 ohm load
DTMF Twist (Balance)		2	3	dB	
DTMF Tone Duration	50	85	255	ms	85ms default
Pulse Dialing Rate	8	10	20	pps	10pps default
Pulse Dialing Make/ Break		39/61		%	US, Canada default
Pulse Interdigit Interval	700		3000	ms	789ms default
Guard Tone Frequency		1800		Hz	Referenced to High Channel Transmit
Guard Tone Amplitude		-9		dB	Referenced to High Channel Transmit
High Channel Transmit Amplitude		-1		dB	Referenced to Low channel, Guard tone enabled
Guard Tone 2 nd Harmonic Distortion		-40		dB	
Call Progress Passband Frequency	205		720	Hz	@ -20 dBm received tone
Wait Time for Dial tone	2		255	sec	Two second default
Return loss @ 1000Hz		15		dB	T _r =600Ω

Table 11. Analog Characteristics.

Name	Type	Characteristic	Value
SPK	O(DF)	Minimum Load	300Ω
		Maximum Capacitive Load	0.01μ
		Output voltage	1.65± .6V

Table 12. CH1786A Pin Functions.
PACKAGE CONNECTION TABLE

PIN NO.	FUNCTION	PIN NO.	FUNCTION
1	RING	12	$\overline{V/D}$
2	TIP	13	\overline{DTR}
3	RXA	14	\overline{DSR}
4	TXA	15	\overline{RI}
5	SPK	16	\overline{CTS}
6	NC	17	\overline{DCD}
7	NC	18	NC
8	\overline{SLEEP}	19	VCC
9	NC	20	GND
10	\overline{TXD}	21	RST
11	\overline{RXD}	22	NC

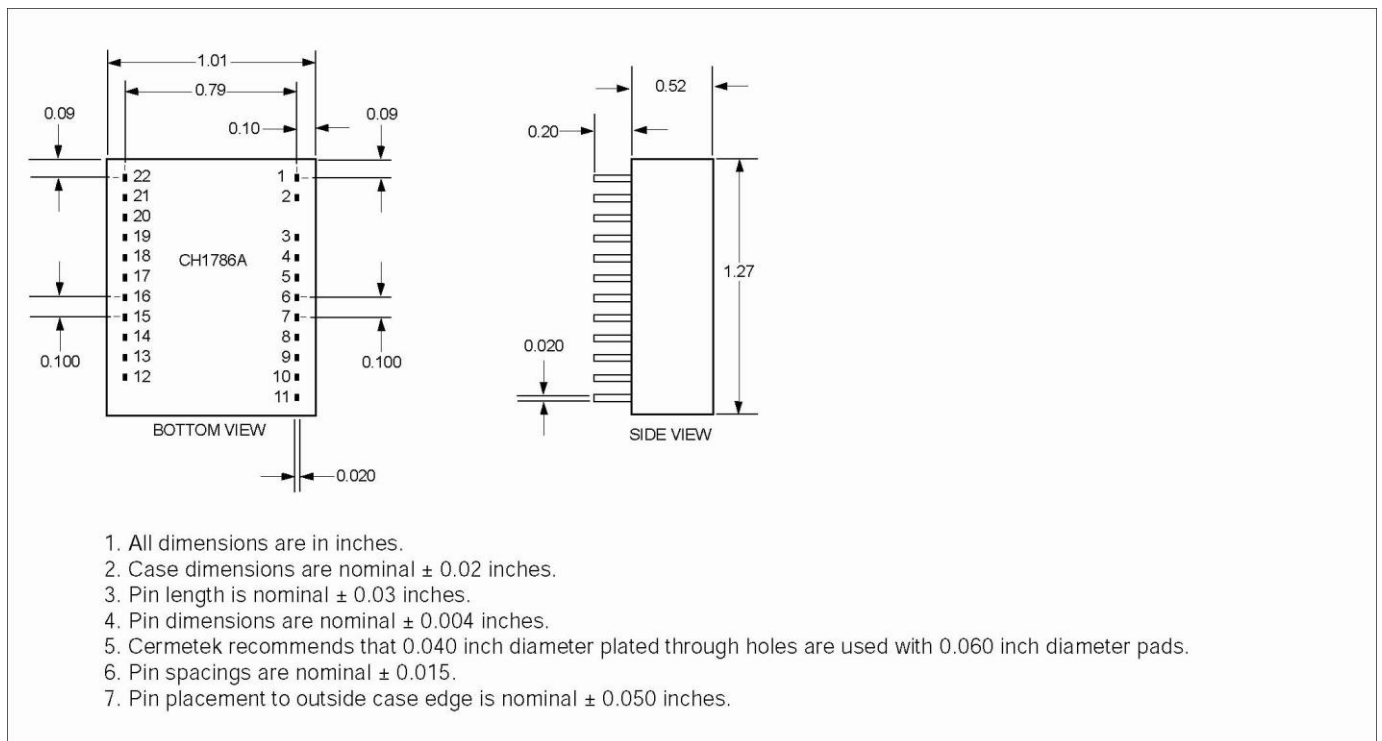

Figure 7. CH1786A Physical Dimensions.

Table 13A. Summary CH1786A Family of Non-RoHS Compliant Products.

Model	Summary of Features	Operating Temperature
CH1786A	Full Function, 2400bps, FCC Part 68 Approved	0°C to + 70°C
CH1786A-C	Full Function with Caller ID (CID), 2400bps, FCC Part 68 Approved	0°C to + 70°C
CH1786A-L	Full Function, 2400bps, FCC Part 68 Approved, No EEPROM, No Internal Surge Protection	0°C to + 70°C
CH1786A-N	Full Function, 2400bps, FCC Part 68 Approved, No EEPROM, No Internal Surge Protection, No 2-4 Wire Converter Circuit (i.e., No Voice Inject Capability)	0°C to + 70°C
CH1786A-P	Full Function with Zero Power Down, 2400bps, FCC Part 68 Approved	0°C to + 70°C
CH1786A-CP	Full Function with Caller ID (CID) and Zero Power Down, 2400bps, FCC Part 68 Approved	0°C to + 70°C
CH1786A ET	Full Function, 2400bps, FCC Part 68 Approved	-40°C to +85°C
CH1786A ET-C	Full Function with Caller ID (CID), 2400bps, FCC Part 68 Approved	-40°C to +85°C
CH1786A ET-P	Full Function with Zero Power Down, 14.4kbps, FCC Part 68 Approved	-40°C to +85°C
CH1786A ET-CP	Full Function with Caller ID (CID) and Zero Power Down, 2400bps, FCC Part 68 Approved	-40°C to +85°C

Table 13B. Summary CH1786A Family of RoHS Compliant Products.

Model	Summary of Features	Operating Temperature
CH1786AR	Full Function, 2400bps, FCC Part 68 Approved	0°C to + 70°C
CH1786AR-C	Full Function with Caller ID (CID), 2400bps, FCC Part 68 Approved	0°C to + 70°C
CH1786AR-L	Full Function, 2400bps, FCC Part 68 Approved, No EEPROM, No Internal Surge Protection	0°C to + 70°C
CH1786AR-N	Full Function, 2400bps, FCC Part 68 Approved, No EEPROM, No Internal Surge Protection, No 2-4 Wire Converter Circuit (i.e., No Voice Inject Capability)	0°C to + 70°C
CH1786AR-P	Full Function with Zero Power Down, 2400bps, FCC Part 68 Approved	0°C to + 70°C
CH1786AR-CP	Full Function with Caller ID (CID) and Zero Power Down, 2400bps, FCC Part 68 Approved	0°C to + 70°C
CH1786AR ET	Full Function, 2400bps, FCC Part 68 Approved	-40°C to +85°C
CH1786AR ET-C	Full Function with Caller ID (CID), 2400bps, FCC Part 68 Approved	-40°C to +85°C
CH1786AR ET-P	Full Function with Zero Power Down, 2400bps, FCC Part 68 Approved	-40°C to +85°C
CH1786AR ET-CP	Full Function with Caller ID (CID) and Zero Power Down, 2400bps, FCC Part 68 Approved	-40°C to +85°C

ATTACHMENT I

Page 1 of 2

Table 14. Cross Compatibility Comparison Chart.

Old (non "A") Model	Equivalent New Model	Comments
CH1786	CH1786A	Standard CH1786A. No Options needed.
CH1786LC	CH1786A-L	No EEPROM, No Internal Surge Protection.
CH1786ET/PD	CH1786A-ET or CH1786A ET-P	Standard extended temp CH1786A. No options needed if Power Down not required. Standard extended temp CH1786A with Power Down option.
CH1786NH	CH1786A-N	No EEPROM, No Internal Surge Protection, No 2-4 wire circuitry (i.e., No voice inject capability).

Table 15. Summary of differences between CH1786 and CH1786A products.

ITEM	CH1786	CH1786A
PIN CONFIGURATION		
PIN 18	HS. LOW indicates 2400bps operation.	Not Supported. No Connect.
IDENTIFICATION COMMANDS		
AT10. Product Code.	242	14400
AT11. ROM Checksum.	192	042
AT12. Checksum Verification.	OK	OK
AT13. Identify current firmware code.	AFES-C2501-H0	CX81802-V32
MODEM OPERATION COMMANDS		
Long Space Disconnect.	ATYn command supports: n=0 Disables long space disconnect (default). n=1 Enables long space disconnect.	Not Supported.
On-Line Echo Character.	ATFn command supports: n=0 Returns ERROR result code. n=1 Returns OK result code (default).	Not Supported.
Test and Diagnostic.	AT&Tn command supports: n=0 Terminates test in progress. n=1 Initiates Analog loopback. n=2 Returns ERROR. n=3 Initiates local Digital loopback. n=4 Enables Digital loopback acknowledgement from remote RDL. n=5 Disables Digital loopback acknowledgement from remote RDL. n=6 Initiates remote Digital loopback. n=7 Initiates remote Digital loopback with self test. n=8 Initiates local Analog loopback with self test.	AT&Tn command supports: n=0 Terminates test in progress. n=1 Initiates Analog loopback. n=2-8 Not Supported.

NOTE: The identification code returned when the **I0**, **I1**, **I3** commands are executed may vary, depending on manufacture date.

ATTACHMENT I

Page 2 of 2

Table 14. Summary of differences between CH1786 and CH1786A products (Continued).

ITEM	CH1786	CH1786A
FAX OPERATION COMMANDS		
Flow Control.	AT+FF command supports: n=0 Disable enhanced flow control (default). EIA-578 standard. n=1 Enables enhanced flow control.	AT+FLO command supports: n=0 XON/XOFF and RTS/CTS flow control turned off (default). n=1 XON/XOFF flow control on in both directions. n=2 Use RTS for flow control of modem by DTE; use CTS flow control of DTE by modem.
Transmit Test Data.	+FTTn=m command.	Not Supported.
Receive Test Data.	+FRTn command.	Not Supported.
NVRAM		
Stored Telephone Number Length	36 digits (maximum)	31 digits (maximum)
STORED PARAMETERS		
Retrieval of factory default profiles.	Execute AT&F or AT&F1 to retrieve Firmware Default setup parameters.	Execute AT&F , AT&F0 or AT&F1 to retrieve Firmware Default setup parameters. To restore the CH1786A to the CH1786 default configuration, the following commands MUST be executed after executing the AT&F , AT&F0 or AT&F1 commands: Enter: AT+MS=V22B,1,300,2400,300,2400<CR> Result: OK Enter: ATS0=1%C0&C1&D0&S1&Q6\N0&Y0&W0<CR> Result: OK

Cernetek reserves the right to make changes in specifications at any time and without notice. The information furnished by Cernetek in this publication is believed to be accurate and reliable. However, Cernetek assumes no responsibility for its use, or for any infringements of patents or other rights of third parties resulting from its use. No license is granted under any patents or patent rights of Cernetek.

Cernetek provides the user with a FCC (USA) and IC (Canada) Approved or device. However, Cernetek does not have influence over nor knowledge of the specific user application environment. Therefore, for FCC and IC Approved or Approvable devices, the user assumes all risk for maintaining compliance to registration.

Printed in U.S.A

