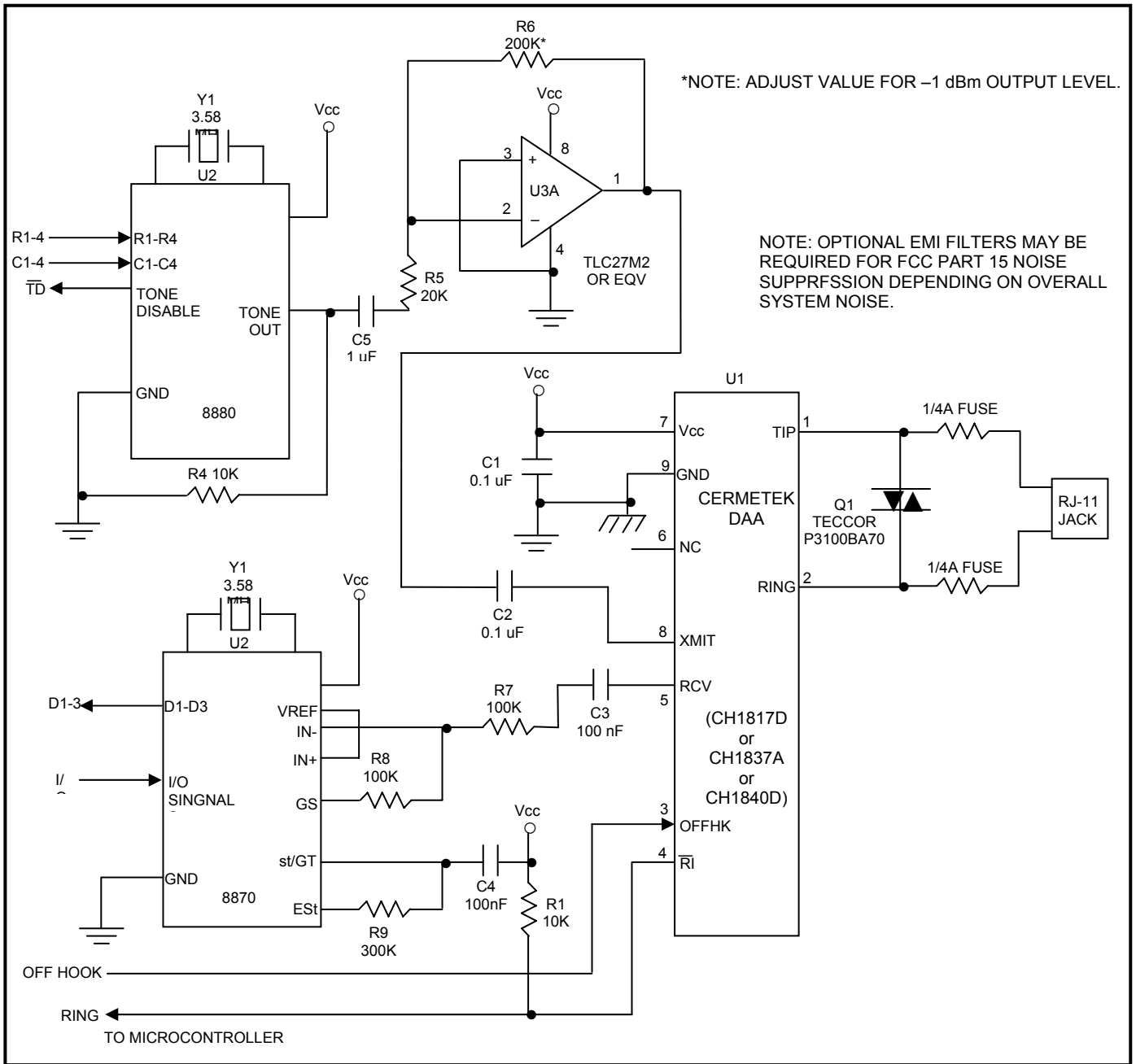

Figure 2. Implementation Using Separate DTMF Transmitter and Receiver Circuits.



Cermetek reserves the right to make changes in specifications at any time and without notice. The information furnished by Cermetek in this publication is believed to be accurate and reliable. However, Cermetek assumes no responsibility for its use, or for any infringements of patents or other rights of third parties resulting from its use. No license is granted under any patents or patent rights of Cermetek.

Printed in U.S.A

406 TASMAN DRIVE | SUNNYVALE CA 94089 | LOCAL: 408-752-5000 | TOLL FREE: 1-800-882-6271
 FAX: 408-752-5004 | WEB SITE: <http://www.cermetek.com> | EMAIL: sales@cermetek.com