

Low-Cost, Low-Speed Surface-Mount Modem

DESCRIPTION

The Cermetek XE2422H is a complete 2400 bps modem in a miniature surface-mount module. It permits the designer to easily incorporate dial-up communications into set top box, security, vending, or point-of-sale applications.

The XE2422H is a complete modem not just a modem chip. Connections to the micro-controller serial port and to the telephone line are all that is required to design-in the XE2422H. As a complete modem, Cermetek includes transferable FCC Part 68 Registration. Eliminating the need for Cermetek customers to under go FCC Part 68 testing.

The XE2422H provides the lowest total cost of ownership. As a complete modem, it eliminates modem design and certification costs. It reduces assembly costs by replacing multiple components with a single, surface-mount module. And all of this is provide at a low per unit cost of less than twenty dollars in volume.

FEATURES

- Small Size: 1.60" by 0.80" by 0.152"
- Data transfer rates from 300 bps to 2400 bps
- Supports V.21, V.22, V.22bis, V.23, Bell 103, Bell 212A modem protocols
- Supports Pulse and FSK Alarm formats
- Serial data rates to 115,200 bps.
- Control and configuration via AT Commands
- 3.3 and 5 volt compatible Serial Interface
- Shared Line Features prevent interference with voice communications on an extension telephone.
- Complete integrated DAA.
- User Transferrable FCC Part 68 Registration
- UL60950 Recognition
- Low Operating Power, 3.3 Volts, 50 mW;
- Sleep Mode with Wake-on-Ring feature
- Power Down reduces current draw to 100 □A

XE2422H BLOCK DIAGRAM

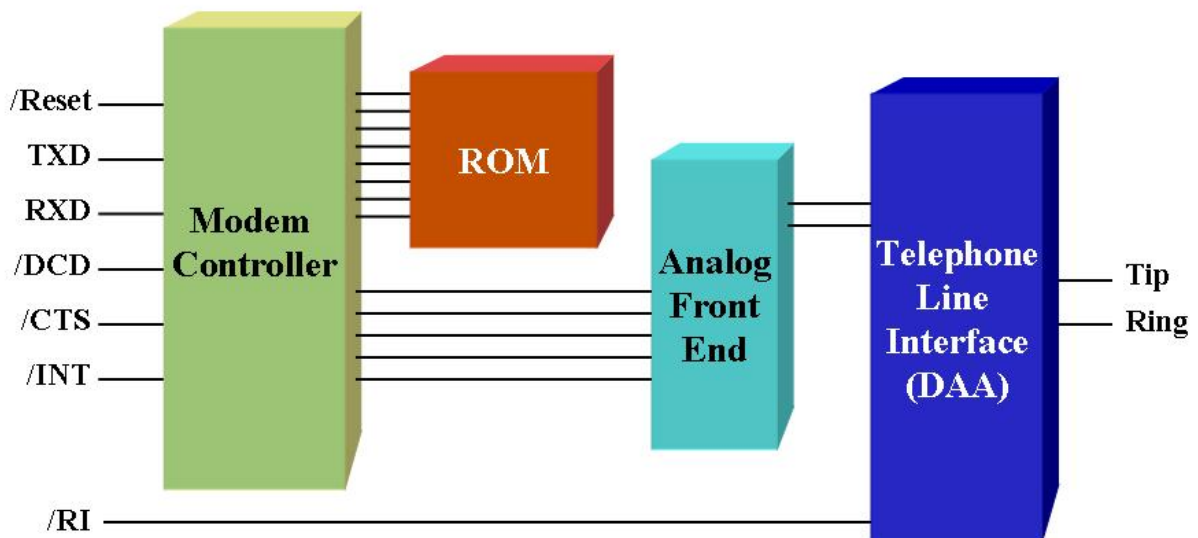

XE2422H Mechanical Specifications

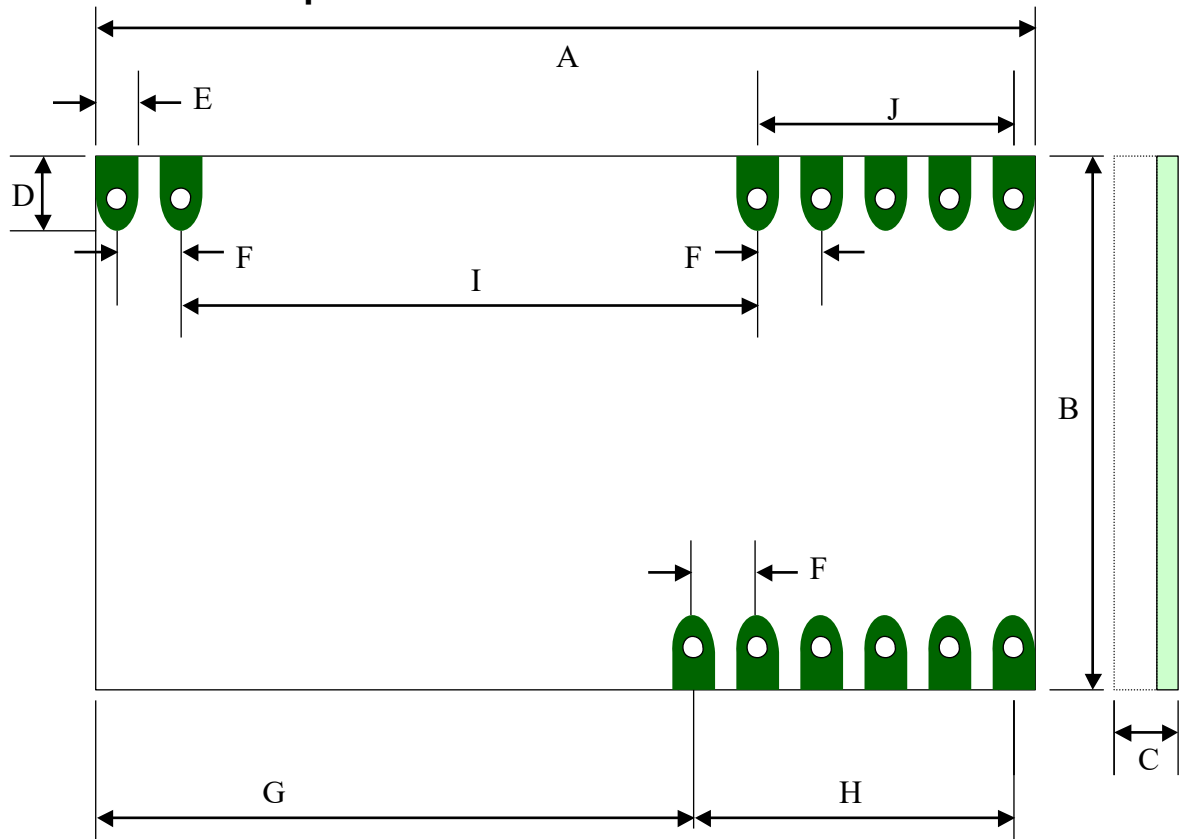

DIMENSIONS	INCHES			MILLIMETERS		
	MIN	TYP	MAX	MIN	TYP	MAX
A	1.595	1.600	1.605	40.51	40.64	40.77
B	0.795	0.800	0.805	20.19	20.32	20.45
C	0.147	0.152	0.157	3.73	3.86	3.99
D	0.095	0.100	0.105	2.41	2.54	2.67
E	0.055	0.060	0.065	1.40	1.52	1.65
F	0.095	0.100	0.105	2.41	2.54	2.67
G	1.045	1.050	1.055	26.54	26.67	26.80
H	0.495	0.500	0.505	12.57	12.70	12.83
I	0.995	1.000	1.005	25.27	25.40	25.53
J	0.395	0.400	0.405	10.03	10.16	10.29

XE2422H Pin Configuration

Top View

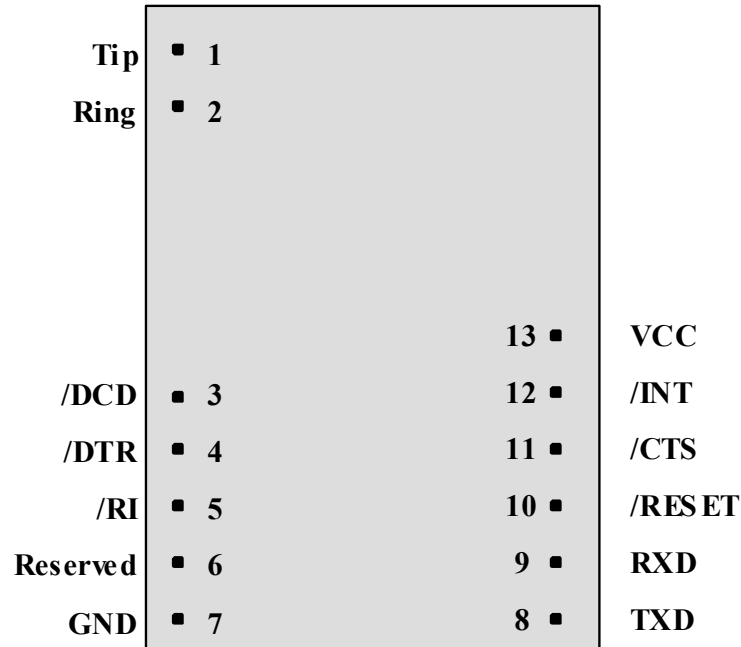

Pin Descriptions

PIN	NAME	DESCRIPTION
1	TIP	<p>The Ring and Tip signals connect the modem to the telephone line. FCC Part 68 Rules require a 1500 volt isolation barrier between the telephone line and all other circuits. This isolation must be preserved throughout the system.</p> <p>The telephone company places a DC “Battery” voltage across Tip and Ring on public switched telephone lines. The XE2422H operates regardless of the polarity of this voltage. The “Battery” voltage drives up to 120 milliampere of DC loop current.</p> <p>UL60950 requires minimum creepage and clearances distances between the Tip and Ring traces and all other circuits. Clearance is the shortest distance between conductive circuits; creepage is the distance between conductive points along the surface</p>
2	RING	<p>The Ring and Tip signals connect the modem to the telephone line. FCC Part 68 Rules require a 1500 volt isolation barrier between the telephone line and all other circuits. This isolation must be preserved throughout the system.</p> <p>The telephone company places a DC “Battery” voltage across Tip and Ring on public switched telephone lines. The XE2422H operates regardless of the polarity of this voltage. The “Battery” voltage drives up to 120 milliampere of DC loop current.</p> <p>UL60950 requires minimum creepage and clearances distances between the Tip and Ring traces and all other circuits. Clearance is the shortest distance between conductive circuits; creepage is the distance between conductive points along the surface.</p>
3	/DCD	<p>/DCD is an active low output from the modem that indicates the presence of a valid carrier signal. The SE2 register controls /DCD in the XE2422H. The default state is for /DCD to be disabled ATSE2=04 enables /DCD.</p>

PIN	NAME	DESCRIPTION
4	/DTR	/DTR is an active low input to the modem. The operation of /DTR is controlled by register SE2 and is normally disabled. When enabled, the modem will exit data mode and enter command mode if /DTR is removed while the modem is on-line. In Pulse and FSK Alarm modes raising /DTR is the only way to disconnect the data link.
5	/RI	The /RI signal reports on the presence of an incoming ring signal. When a ring occurs across Tip and Ring, the /RI output goes low and toggles with the cadence of the ring signal. /RI is controlled by register S0D bit 6. The default condition is for /RI to be disabled.
6	RESERVED	Reserved for future use
7	GROUND	Ground provides the reference voltage for all host interface signals.
8	TXD	TXD provides the path for transmitted data and modem commands to be passed from the host controller to the modem. A logic high on TXD represents a "Mark" condition and a logic low represents a "Space" condition.
9	RXD	RXD provides the path for received data and modem responses to be sent from the modem to the host controller. A logic high on RXD represents a "Mark" condition and a logic low represents a "Space" condition.
10	/RESET	/RESET is an active low input which initiates a modem hardware reset.
11	/CTS	/CTS is an active low output from the modem. The modem asserts /CTS to indicate that it can accept data from the terminal equipment on TXD.
12	/INT	/INT provides an active low hardware interrupt signal from the XE2422H. The operation of this interrupt pin is programmable using registers SE2 and S08. /INT can be programmed to indicate Loss of Carrier, Wake-on-Ring, Loss of Loop Current, or Shared Line Activity. Once triggered the /INT line remains active until cleared by the AT:I command.
13	VCC	VCC provides 3.3 volt power to the modem.

XE2422H Electrical Specifications

PARAMETER	MIN	TYP	MAX	UNITS	COMMENTS
VCC	3.0	3.3	3.6	VOLTS	
ICC		15		mA	On-Line
		10		mA	Sleep
		1		mA	Power Down
RING VOLTAGE DETECT	26		150	VRMS	Type B Ringer
RING FREQUENCY DETECTED	15.3		68	Hz	Type B Ringer
TELEPHONE LOOP CURRENT	16	40	120	mA	
LINE IMPEDENCE		600		Ohms	
DATA TRANSMIT LEVEL			-9.0	dBm	
DTMF TRANSMIT LEVEL		-2.5	0	dBm	Average over a 3 second interval
Voh	2.4			Volts	
Vol			0.4	Volts	
Vih	2.0		5.0	Volts	
ViL	-0.3		0.8	VCC	

XE2422H Surface-Mount Soldering Instructions

The XE2422H is subject to damage if overexposed to heat during solder reflow operations. Following the soldering instructions below will ensure that the process of soldering the module to the board does not damage the modem.

Maximum Temperature	235° C
Maximum Time at 235° C	15 Seconds
Maximum Time above Eutectic (150° C)	90 Seconds
Maximum Preheat Dwell Time	180 Seconds

Maximum Recommended Solder Temperature Profile

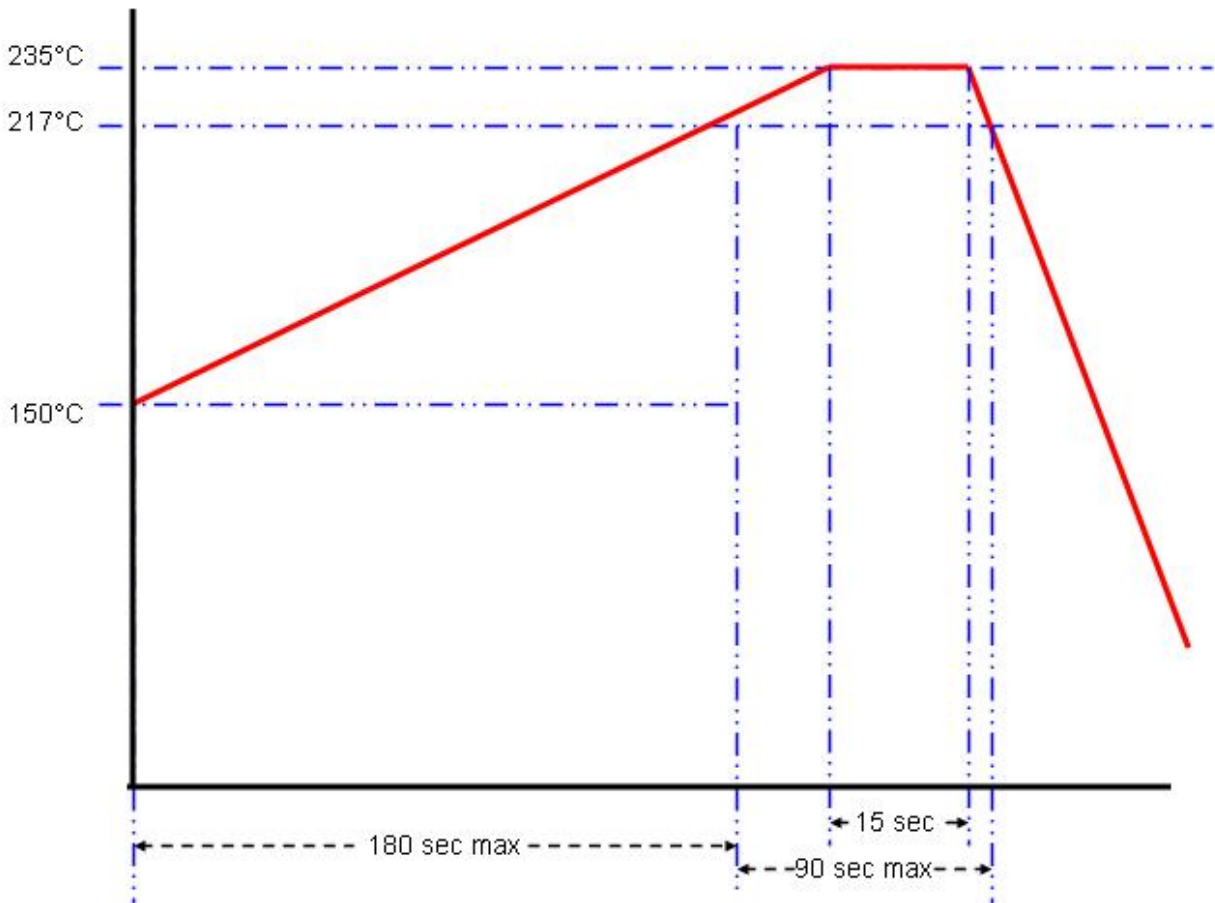

XE2422H Recommended Landing Pattern

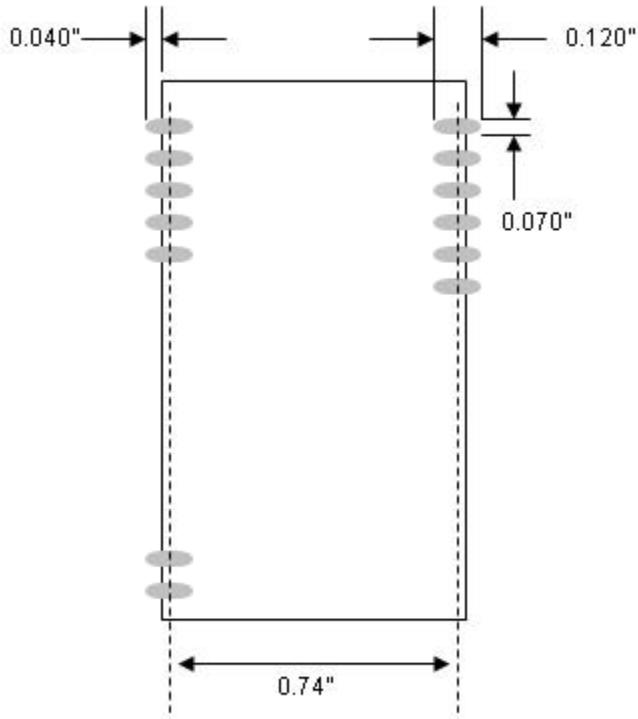

Pad Dimensions: Oval 0.130 inches by 0.070 inches
Pad Extensions beyond XE2422H PCB: 0.040 inches
Row Center to Center: 0.74 inches

Warning: No Vias, Traces or other Copper should be placed under the XE2422H module

XE2422H Typical Connection Diagram

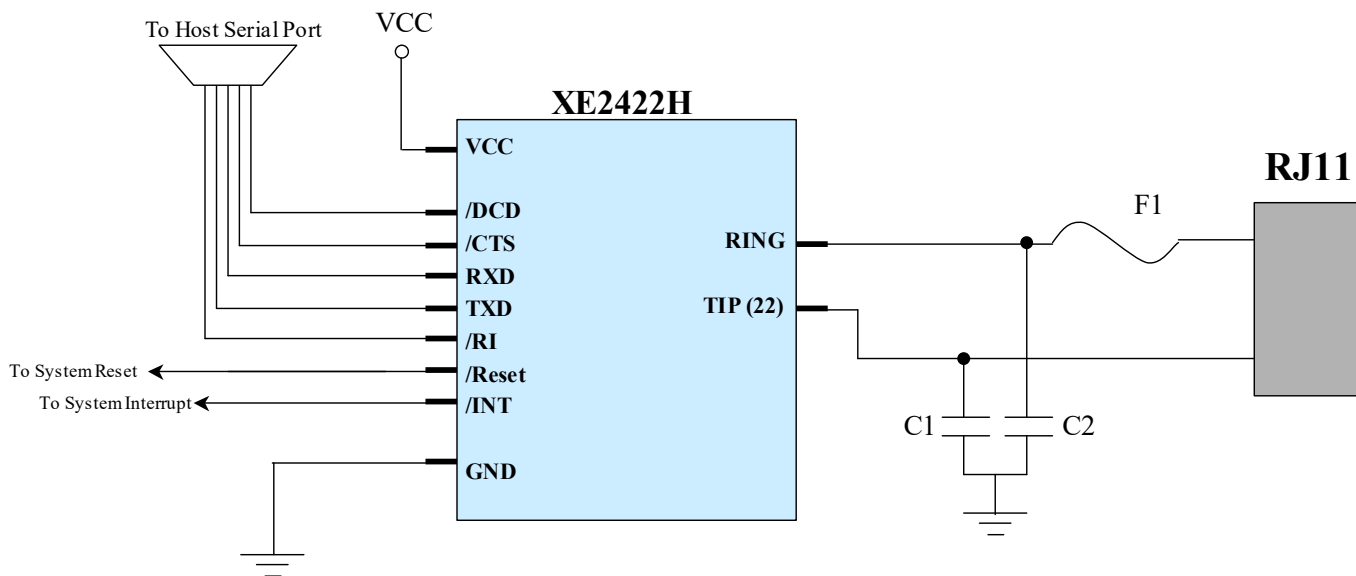

Parts List for XE2422H Typical Connection Diagram

Reference Designation	Qty	Description
C1, C2	2	Cap, 1000 pFd, 1500 V minimum
F1	1	PTC, TR600-150

Notes:

- Capacitors, C1 and C2, may be required for EMI filtering in your system. Without these components you may experience unintended radiation when the telephone cable is attached. C1 and C2 are high-voltage capacitors. We recommend the Johanson Dielectrics 502S47N102KV6T. This 1000 pfd, 3000 volt capacitor will direct the high frequency harmonics to the system ground. These capacitors must be rated at a minimum of 1500 volts to maintain the isolation required by FCC Part 68 Rules.
- F1 is a positive thermal coefficient (PTC) device which protects the modem from excessive current flow. These devices are required for your system to pass UL60950. Fuses may be used in place of the PTC's

XE2422H DESIGN NOTES

The following design notes are intended to assist the developer in achieving maximum utility from the XE2422H modem module.

XE2422H Shared Line Features

The XE2422H includes the ability to monitor telephone line conditions before, after and during calls. This allows the XE2422H to avoid conflicts with other equipment connected to the telephone line. There are two modes of operation for the XE2422H Shared Line Features; Connect Detect and Handset Interrupt.

Connect Detect

The XE2422H register SDB monitors the voltage level on the telephone line when the modem is on-hook. The XE2422H checks the value of register SDB before attempting to go off-hook to avoid interrupting a call in progress. The nominal value for loop voltage on the telephone line is typically 48 volts. A reduced voltage level indicates that the line is either disconnected from the modem or is currently in use.

Register SDB is an 8 bit register. It stores the loop voltage as a 2's complement number with each bit representing 1 volt. The Most Significant Bit represents the polarity of the loop voltage.

Handset Interrupt:

Handset Interrupt permits the modem to yield the telephone line when other equipment connected to the telephone line goes off-hook. This prevents the modem from blocking outgoing emergency calls when the line is shared as in a residential application. Handset Interrupt is accomplished by monitoring the loop current through the modem while the modem is off-hook. The loop current will drop when another piece of equipment goes off-hook on the same telephone line.

The XE2422H constantly monitors and stores the loop current value in Register SF3 in 1.1 milliamp increments. The value of SF3 is regularly updated. The value of SF3 is compared to the Handset Interrupt threshold in register S12. If the value of SF3 is lower than the value of S12 by at least the amount of the Handset Interrupt Differential Current Threshold, S11, then the XE2422H assumes the equipment on an extension telephone has gone off-hook. The modem then issues the Handset Interrupt response "i" and if so configured issues an Interrupt to the systems host controller. The host controller determines if the call should be terminated to yield the telephone line to the extension.

XE2422H AT Commands

The XE2422H uses a simplified "AT" command set for configuration and control. This section describes the AT command format and lists the AT commands, registers and result codes. XE2422H "AT" commands have three operational modes; command mode, alarm mode and data mode. The Data Rate for the XE2422H is set by Register SE0.

Data Mode: The XE2422H enters data mode after it connects to a remote modem and issues the appropriate result code. In the data mode the modem sends all data presented on Transmit Data (TXD) to the remote modem and puts data from the remote modem onto Received Data (RXD). When the modem exits data mode, it issues a "NO CARRIER" result code.

Command Mode: The XE2422H enters command mode on power-up, reset, a lost connection, or receipt of the escape code. In command mode the modem accepts commands from the host on transmit data. Appropriate result codes are returned on RXD.

Command Line Format

Command lines issued to the modem follow a strict format. Each command line begins with the prefix AT. All commands except the “z” command must be entered in upper case characters. The command line is a string of commands between the AT prefix and the carriage return which terminates the command. The command buffer stores the command line and executes it upon receipt of a carriage return. Commands will be executed in the sequence they appear in the command line.

Result Codes - The modem issues a result code after each command line. Result codes may be sent as single characters or single characters followed by a carriage return.

Alarm Mode:

The XE2422H supports a unique set of commands to establish alarm industry connections. Both Pulse messaging and FSK formats are supported. The AT!1 command initiates Pulse messaging and AT!2 initiates FSK messaging. The ATD command must precede either AT! command to begin the Alarm transaction. In Alarm mode, /DTR must be removed to disconnect the modem link. /DTR is activated by setting register SE2 bits 4 and 5.

Pulse Mode: In Pulse Mode messages are passed using DTMF tones. The receiving station acknowledges receipt of the message by transmitting the “Kissoff” tone. A sample transaction is shown below.

Alarm Panel **XE2422H**

ATDT#!1<message 1><CR>

K

!<message 2><CR>

K

!<message n><CR>

K

Disconnect is accomplished by raising /DTR.

FSK Mode: In FSK Mode messages are passed on a 300 bps, half-duplex carrier signal. The X1, X2, and X3 commands switch the modem between monitoring the line for acknowledgments (X1), transmitting messages (X2), and receiving messages (X3). As in the pulse mode disconnect is only possible by pulling the /DTR signal high.

XE2422H AT Commands

An asterisk indicates the factory default

A - Answer Command -

D - Dial Command -

0-9, A-D, #, * = Dialing Digits

P = Pulse dial

T = Tone dial

, = Pause for two seconds

l = Pause for 125 milliseconds

; = Return to the command state

En - Command Echo

n=0 Do not echo commands

n=1 Enable command echo *

Hn - Switch Hook Control -

n=0 Switch hook relay opens

n=1 Switch hook relay closes

In - Modem Identification

:I Read Interrupt Register - Read and reset the interrupt status register S09

O - Return On Line

SR? - Read Value of register R

SR=n - Write value "n" into register "R".

The values of both "n" and "R" are hexadecimal.

Vn - Result Codes -

n=0 Single Character Result Codes

n=1 Result Codes followed by a Carriage Return*

Z - Reset -

z - Wake from Sleep Mode on Ring

!1<message> - Switch to Pulse Mode: This command must follow the dialing command in the same command string.

!2<message> - Switch to FSK Mode: This command must follow the dialing command in the same command string. This command allows the modem to establish a 300 bps half-duplex FSK signal.

X1 - FSK Signal Search: Turns off the modem transmitter and monitors the line for an acknowledgment.

X2 - Return On-line as Transmitter: Places the modem in the transmit mode during FSK half-duplex operation.

X3: - Return on-line as Receiver: Places the modem in the receive mode during FSK half-duplex operation.

~ - Resend Last Pulse Mode Message:

XE2422H RESPONSES

Result Code Description

a	British Caller ID Tone Detected
b	Busy Tone Detected
c	Connect
d	Connect 1200
f	Battery Voltage Reversal Detected
H	Modem automatically hung up in Security Mode
I	Parallel Handset Returned On-Hook
i	Handset Interrupt Detected
K	Kissoff Tone Detected in Security Mode
k	Kissoff Tone exceeds Limit set by S36
L	Phone Line Detected
l	No Phone Line Detected
m	Caller ID Signal Detected
N	No Carrier Detected
n	No Dial Tone
O	OK Response
R	Ringing
r	Ringback Tone Detected
t	Dial Tone Detected
x	Over-current Condition Detected
v	Connect in V.23 originate mode
^	Kissoff Tone Detection Required
,	Dialing Complete

XE2422H REGISTER SETTINGS

XE2422H register values are stored in Hex format. An asterisk "*" signifies the default setting of a bit-mapped register.

S00 Answer on nth Ring: S00 sets the modem to automatically answer on the nth ring. Setting S00 to 0 disables automatic answer.

.. Range: ..00 to 7F (0 to 127 rings)

.. Units.....Rings

.. Default...00 (Auto Answer Disabled)

S01 Wait to Dial: S01 determines the maximum time the modem will wait to dial

.. Range: ..0 to 6D (0 to 109 seconds)

.. UnitsSeconds

.. Default...02 (2 seconds)

S02 Wait for Dial Tone S02 determines how long the modem waits for Dial Tone before hanging up.

Range: ..00 to 6D (0 to 109 seconds)

.. Units.....Seconds

.. Default...03 (3 seconds)

S03 Carrier Off Disconnect Delay: S03 determines how long carrier must be lost before modem disconnect.

.. Range: ..00 to 7F (0 to 6.78 seconds)

.. Units.....0.0533 Seconds

.. Default...0E (0.75 seconds)

S04 DTMF Duration and Spacing: S04 sets duration and spacing of DTMF dialing tones.

.. Range: ..00 to 7F (0 to 211 milliseconds)

.. Units.....1.666 milliseconds

.. Default...30 (80 milliseconds)

S05 Duration Off-Hook during Pulse Dialing: S05 defines how long the hookswitch is active between dialing pulses.

.. Range: ..00 to 7F (0 to 211 milliseconds)

.. Units.....1.666 milliseconds

.. Default...18 (40 milliseconds)

..

S06 Duration of Dialing Pulses: S06 determines how long the modem goes on-hook to generate dialing pulses....

.. Range: ..00 to 7F (0 to 211 milliseconds)

.. Units1.666 milliseconds

.. Default...24 (60 milliseconds)

S07 Modem Protocol Selection: S07 sets the protocol and speed of the modem connection.

<u>Protocol</u>	<u>Data Rate</u>	<u>Register Value</u>
V.22bis	2400 bps	06 *
V.22	1200 bps	02
V.21	300 bps	03
Bell 212A	1200 bps	00
Bell 103	300 bps	01

S08 Interrupt Control Register: S08 is a bit-mapped register which defines the events that will cause the /INT signal to be activated. Default = 00

<u>Bit #</u>	<u>Definition</u>	<u>Action</u>
7	Issue Interrupt when Carrier Detect is lost	0 = No Interrupt * 1= Activate Interrupt
6	Issue Interrupt on Ring with Wake-on-Ring selected	0 = No Interrupt * 1= Activate Interrupt
5	Issue Interrupt on Handset Interrupt Detection	0 = No Interrupt * 1= Activate Interrupt
4	Issue Interrupt on No Connect Detection	0 = No Interrupt * 1= Activate Interrupt
3	Issue Interrupt on Ring Detection	0 = No Interrupt * 1= Activate Interrupt
2	Issue Interrupt on Caller ID	0 = No Interrupt * 1= Activate Interrupt
1	Issue Interrupt on Over-current Detection	0 = No Interrupt * 1= Activate Interrupt
0	Reserved	

S09 Interrupt Status Register: S09 is a bit-mapped register. The active bit indicates the cause of the most recent interrupt. S09 is cleared when read on receipt of the :I command. Default = 00

<u>Bit #</u>	<u>Definition</u>
.. 7	Interrupt issued when Carrier Detect was lost
.. 6	Interrupt issued when a Ring was detected with Wake-on-Ring selected
.. 5	Interrupt issued on Handset Interrupt Detection
.. 4	Interrupt issued on No Connect Detection
.. 3	Interrupt issued on Ring Detection
.. 2	Interrupt issued on Caller ID
.. 1	Interrupt issued on Over-current Detection
.. 0	Reserved

S0C Modem Function Register: S0C is a bit-mapped register which controls the designated modem functions. Default = 00

<u>Bit #</u>	<u>Definition</u>	<u>Action</u>
.. 7	Enable Carrier Detect IO pin	0 = No DCD output * 1 = DCD Active
.. 6	Reserved	
.. 5	Enable Caller ID	0 = No Caller ID * 1 = Caller ID Active
.. 4:3	Reserved	
.. 2	Blind Dialing, dialing without detecting dial tone	0 = Dial Tone Required * 1 = Blind Dialing Selected
.. 1:0	Reserved	

S0D Modem Function Register: S0D is a bit-mapped register which controls the designated modem functions. Default = 00

<u>Bit #</u>	<u>Definition</u>	<u>Action</u>
.. 7	Reserved	
.. 6	Enable Ring Indicate IO pin	0 = No RI output * 1 = RI Active
.. 5:4:3	Reserved	
.. 2	Disconnect upon detection of a Busy Signal	0 = Disabled * 1 = Hang-up on Busy Detect
.. 1	Disconnect on Handset Interrupt detection	0 = Disabled * 1 = Enabled
.. 0	Reserved	

- S0E Pulse Dialing Interdigit Delay:** S0E determines the length of the time between numbers dialed using dialing pulses. The minimum time between digits is 64 milliseconds. The value of S0E adds to that 64 millisecond delay in 10 millisecond increments
- .. Range: ..00 to 7F (64 to 1374 milliseconds)
 - .. Units.....10 milliseconds
 - .. Default...46 (764 milliseconds)
- S0F Escape Character:** S0F defines the character to be used in the escape sequence to move from data mode to command mode. Values of 0 to 127 select valid ASCII characters.
- .. Range: ..00 to 7F
 - .. Units.....ASCII Character
 - .. Default...2B (+)
- S10 Escape Code Guard Timer:** S10 defines the duration of the guard timer surrounding the escape sequence. The guard time is the time preceding and following the escape sequence during which any character received by the modem will abort the escape sequence.
- .. Range: ..00 to 7F (0 to 6.78 seconds)
 - .. Units.....0.0533 Seconds
 - .. Default...13 (1 second)
- S11 Handset Interrupt Differential Current Threshold:** S11 sets the differential loop current threshold for the XE2422H handset Interrupt detection algorithm. If loop current falls by the value of S11 below the value of S12, Handset Interrupt is activated.
- .. Range: ..00 to 07 (0 to 7 milliamps)
 - .. Units.....1 Milliamp
 - .. Default...04 (4 milliamps)
- S12 Handset Interrupt Current Threshold:** S12 sets the loop current threshold for the XE2422H Handset Interrupt detection algorithm. If loop current falls by the value of S11 below the value of S12, Handset Interrupt is activated.
- .. Range: ..00 to 64 (0 to 100 milliamps)
 - .. Units.....1 Milliamp
 - .. Default...00 (0 milliamps)

S15 Modem Link Control Register: S15 selects modem guard tones, calling tones and data format..
Default = 04

<u>Bit #</u>	<u>Definition</u>	<u>Action</u>
7	Reserved	
6	Transmit V.25 Calling Tone	0 = Disabled * 1 = Calling Tone Active
5	Transmit 550 Hz Guard Tone	0 = Disabled * 1 = 550 Hz Guard tone Active
4	Transmit 1800 Hz Guard Tone	0 = Disabled * 1 = 1800 Hz Guard tone Active
3	Number of Stop Bits	0 = 1 Stop Bit * 1 = 2 Stop Bits
2:1	Number of Data Bits	00 = 6 Data Bits 01 = 7 Data Bits 10 = 8 Data Bits * 11 = 9 Data Bits
0	Reserved	

S29 Handset Interrupt Blocking Time: S29 provides a set duration for blocking the Handset Interrupt feature to avoid false detections. This timer is activated by S82.

.. Range: ..00 to 7F (0 to 63.5 Seconds)
.. Units.....0.5 Seconds
.. Default...00 (disabled)

S37 Carrier Detect Recovery Time: S37 determines how long after being lost the data carrier signal must be detected before the modem recognizes it as being recovered.

.. Range: ..00 to 7F (0 to 211 milliseconds)
.. Units.....1.66 milliseconds
.. Default...20 (53.33 milliseconds)

S39 Carrier Detect Response Time: S39 determines how long the modem will wait for the initial data carrier signal to be detected before aborting a call..

.. Range: ..00 to 7F (0 to 127 Seconds)
.. Units.....1 Second
.. Default...3C (60 Seconds)

S62 Result Code Register: S62 allows selection of specific modem result codes. Default = 41

<u>Bit #</u>	<u>Definition</u>	<u>Action</u>
7	Reserved	
6	Over-current Result code "x"	0 = Result Code "x" supported 1 = Disabled *
5:4:3	Reserved	
2	Handset Interrupt Result Codes "I" and "i"	0 = Disabled * 1 = Support result codes "I" and "i"
1	Connect Detect Result Codes "L" and "l"	0 = Disabled * 1 = Support result codes "L" and "l"
0	Ring Result Code "R"	0 = Disabled 1 = Result Code "R" supported

S82 Loop Current Register: S82 allows selection of specific modem result codes. Default = 08

<u>Bit #</u>	<u>Definition</u>	<u>Action</u>
7:6:5:4	Reserved	
3	Detect Loss of Loop Current	0 = Disabled 1 = Enabled *
2:1	Block Handset Interrupt on initial connection	00 = No Handset Interrupt Blocking * 01 = Blocked during dialing 10 = Blocked unit S29 Time out 11 = Blocked unit Carrier Detect
0	Reserved	

SDB Line Voltage Status: SDB is a read only register that stores the value of the loop voltage in two's compliment form. The most significant bit, Bit 7, indicates the polarity of the voltage on Tip and Ring.

Units.....1 Volt

Default...00 (Tip and Ring Voltage less than 3 volts)

SE2 Interrupt Enable: SE2 activates the XE2422H Interrupt output. Default = 00

<u>Bit #</u>	<u>Definition</u>	<u>Action</u>
7:6	Interrupt Output Control	00 = Disabled *
		01 = Disabled
		10 = Disabled
		11 = Interrupt Output Enabled
5:4	/DTR Control	00 = Disabled *
		01 = Disabled
		10 = Disabled
		11 = /DTR Enabled
3:2	/DCD	00 = /DCD Disabled*
		01 = /DCD Enabled
		10 = /DCD Disabled
		11 = /DCD Disabled
1:0	Reserved	

SF1 Power Down Register: SF1 allows the XE2422H to be placed in power down mode. The modem draws only about 100 microamps in Power down mode. Default = 0C

<u>Bit #</u>	<u>Definition</u>	<u>Action</u>
7	Reserved	
6	Power Down Mode	0 = Normal Operation
		1 = Power Down Selected
5:4	Reserved	
3:2	Forced Active	
1:0	Reserved	

SF3 Loop Current Status: SF3 is a read only register that stores the current value of the loop current.

.. Units.....1.1 milliamps
 .. Default...00 (no Loop Current Present)

..

FCC Instructions

The XE2422H complies with Part 68 of the FCC Rules and Regulations. With each device shipped, there is a label which contains the FCC Registration Number. The FCC Registration number incorporates the Model Number, Manufacturer Identifier, Product Type identifier and Ringer Equivalence Number (REN) for this product. You must, upon request, provide this information to your telephone company. The format of the FCC Registration Number is shown below.

The mounting of this device in the final assembly must be made in such a manner as to preserve the high voltage protection between the TIP/RING Connection and the rest of the system. Typically, this may be accomplished by maintaining a minimum spacing 100 mils between the TIP/RING Traces to the RJ-11C Jack and low voltage portion of the system. No additional circuitry may be attached between TIP/RING and the telephone line connection, unless specifically allowed in the rules.

The REN is useful to determine the quantity of devices you may connect to a telephone line and still have all of these devices ring when the number is called. In most, but not all areas, the sum of the RENs of all devices connected to one line should not exceed five (5.0). To be certain of the number of devices you may connect to the line, as determined by the REN, you should contact the local telephone company to determine the maximum REN for you calling area.

If your system causes harm to the telephone network, the telephone company may discontinue service temporarily. If possible, they will notify you in advance. If advance notification is not practical, you will be notified as soon as possible.

Your telephone company may make changes in its facilities, equipment, operations or procedures that could affect proper functioning of your equipment. If they do, you will be notified in advance to give you an opportunity to maintain uninterrupted telephone service.

If you experience trouble with this device, please contact CERMETEK at (408) 945-6640 for information on obtaining service or repairs. The telephone company may ask you to disconnect this device from the network until the problem has been corrected or until you are sure that the device is not malfunctioning.

Terms of Sale

Devices sold by Cermetek are covered by the warranty provisions appearing in its Terms of Sale only. Cermetek makes no warranty, express, statutory, implied, or by description regarding the information set forth herein, or regarding the freedom of the described devices from patent infringement. Cermetek makes no warranty of merchantability or fitness for any purposes. Cermetek reserves the right to discontinue production and change specifications and prices at any time and without notice. This product is intended for use in normal commercial applications. Applications requiring extended temperature range, unusual environmental requirements, or high reliability applications, such as military, medical life-support or life-sustaining equipment, are specifically not recommended without additional processing and authorization by Cermetek for such application.

Cermetek assumes no responsibility for the use of any circuitry other than circuitry embodied in a Cermetek product. No other circuits, patents, or licenses are implied.

Life Support Policy

Cermetek products are not authorized for use as Critical Components in Life Support Devices or Systems.

Life Support Devices or Systems are devices or systems which, (a) are intended for surgical implant into the body, or (b) support or sustain life, and whose failure to perform, when properly used in accordance with instructions provided in the labeling, can be reasonably expected to result in significant injury to the user.

A Critical Component is any component of a life support device or system whose failure to perform can be reasonably expected to cause failure of the life support device or system, or to affect its safety or effectiveness.

Copyright, Cermetek Microelectronics Inc. 2011

While Cermetek Microelectronics, Inc. has made every effort to ensure that the information presented here is accurate, Cermetek will not be liable for any damages arising from errors or omission of fact. Cermetek reserves the right to modify specifications and/or prices without notice. Product mentioned herein are used for identification purposes only and may be trademarks and/or registered trademarks of their respective companies.

Cermetek Microelectronics, Inc.
374 Turquoise Street, Milpitas, CA 95035

