

World's Smallest Global V.22 Modem

Description

The Xecom XE2400G is a complete, global modem in a PLCC-68 compatible package. Xecom designed the XE2400G to supply embedded applications with an easy to integrate dial-up communications solution.

Xecom includes transferable FCC Part 68 Registration to XE2400G users. This allows the embedded system designer to add modem communications to his process control, remote monitoring, point-of-sale, or remote diagnostic system without adding FCC testing.

Only Xecom offers a family of surface-mount, modular modems. The XE2400G package is the smallest complete modem. Xecom also offers a pin compatible module supporting both V.92 data and V.17 fax transfer the XE5617G. This provides the flexibility to switch modem modules to meet changing market requirements.

Models

- XE2400G - V.22bis, PLCC-68 package

Features

- Small Size: HyPLCC™ measures less than 1 inch by 1 inch and is just 0.29 inches thick
- Data transfer at rates from 300 bps to 2400 bps
- Modem Control and Configuration via industry standard AT Commands.
- 3.3 and 5 volt compatible Serial Interface
- Supports V.42 and MNP error correction
- Shared Line Features prevent modem operation from interfering with voice communications.
- Nonvolatile memory stores modem configuration.
- Complete integrated DAA.
- User Transferrable FCC Part 68 Registration
- Complies with telephone networks around the world.
- UL60950 compliant
- 3.3 Volt Power operation;

XE2400G BLOCK DIAGRAM

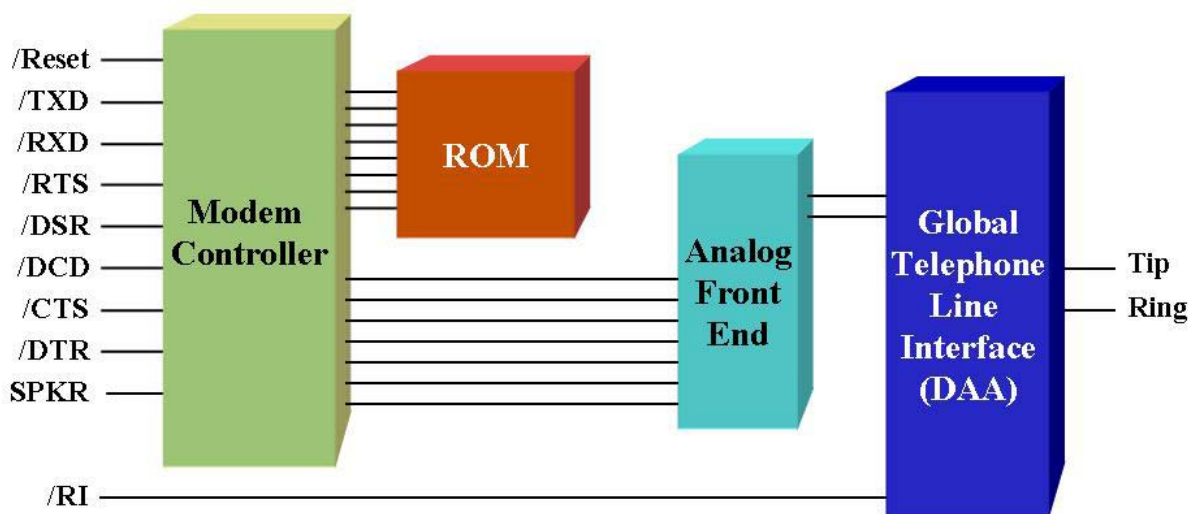

XE2400G Mechanical Specifications

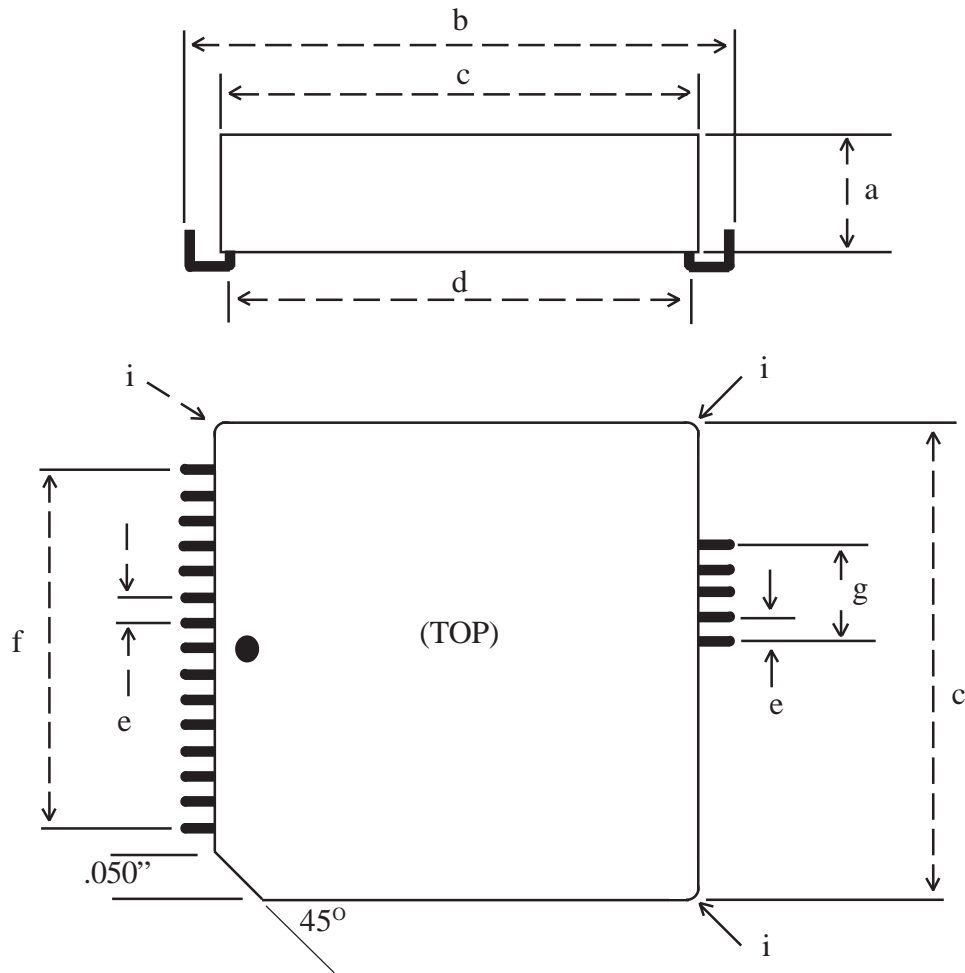

Dimension	Inches			Millimeters		
	Min	Typ	Max	Min	Typ	Max
a	0.280	0.285	0.290	7.11	7.24	7.37
b	0.985	0.990	0.995	25.02	25.15	25.27
c	0.950	0.955	0.960	24.13	24.26	24.38
d	0.910	0.920	0.930	23.11	23.37	23.62
e	0.045	0.050	0.055	1.15	1.27	1.40
f	0.695	0.700	0.705	17.65	17.78	17.91
g	0.195	0.200	0.205	10.03	10.16	10.29
i(radius)	0.015	0.020	0.025	0.13	0.25	0.38

XE2400G Pin Configuration

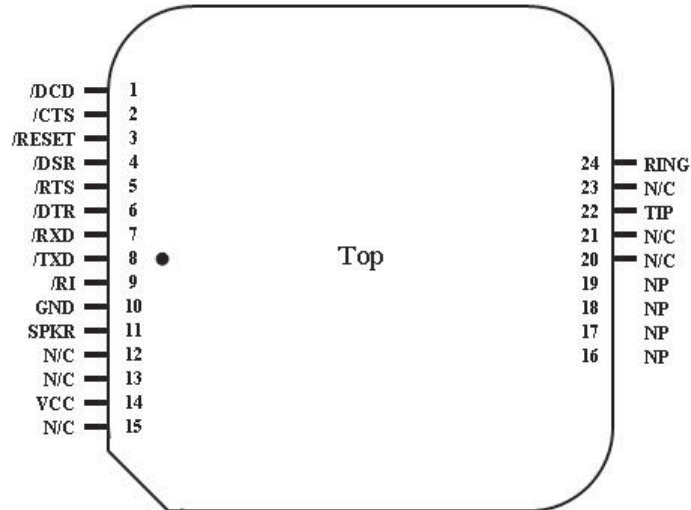

Pin Descriptions

PIN	NAME	DESCRIPTION
1	/DCD	/DCD is an active low output from the modem. This activity on /DCD is controlled by the AT&C command. In the default state, AT&C1, /DCD indicates the presence of a valid carrier signal.
2	/CTS	/CTS is an active low output from the modem. When hardware flow control is active, the modem asserts /CTS to indicate that it can accept data from the terminal equipment on /TXD.
3	/RESET	/RESET is an active low input which initiates a modem hardware reset. /RESET must be active for a minimum of 100 milliseconds for a proper modem reset sequence. No external reset is required; if none is used the /RESET signal should be left open.
4	/DSR	/DSR is active low output from the modem. The /DSR signal typically indicates that the modem has established a communications link. The AT&S command determines the activity on /DSR..
5	/RTS	/RTS is an active low input to the modem. When hardware flow control is active, /RTS indicates to the modem that the host has data to send.
6	/DTR	/DTR is an active low input to the modem and is controlled by the AT&D command. The default setting, AT&D2, causes the modem to interpret the activation of /DTR as an indication that the host equipment is ready to communicate. If /DTR is deactivated while the modem is on-line, the modem will immediately disconnect and enter command mode.
7	/RXD	/RXD provides the path for received data and modem responses to be sent from the modem to the host terminal equipment.

XE2400G Pin Descriptions (continued)

PIN	NAME	DESCRIPTION
8	/TXD	/TXD provides the path for transmitted data and modem commands to be passed from the host terminal equipment to the modem.
9	/RI	The /RI signal reports on the presence of an incoming ring signal. When a ring occurs across Tip and Ring, the /RI output goes low and toggles with the cadence of the ring signal.
10	Ground	Ground provides the reference voltage for all host interface signals.
11	SPKR	SPKR allows connection of a speaker to monitor modem operations. SPKR cannot directly drive a speaker. An amplifier with a minimum input impedance of 300 ohms is required. The signal on SPKR is controlled by the ATM command.
12, 13	N/C	No internal connection
14	VCC	VCC provides 3.3 volt power to the modem.
15	N/C	No internal connection
16-19	NP	No Pin
20-21	N/C	No internal connection
22	Tip	<p>The Ring and Tip signals provide modem the connection to the telephone line. FCC Part 68 Rules require a 1500 volt isolation barrier between the telephone line and all other circuits. This isolation must be preserved throughout the system.</p> <p>The telephone company places a DC “Battery” voltage across Tip and Ring on all public switched telephone lines. The XE2400G will operate regardless of the polarity of this “Battery” voltage. The “Battery” voltage drives up to 100 milliamps of DC loop current.</p> <p>UL60950 requires minimum creepage and clearances distances be maintained between the Tip and Ring traces and all other circuits. Clearance is the shortest distance between conductive circuits; creepage is the distance between conductive surfaces along the surface</p>
23	N/C	No internal connection, To prevent damage in case of voltage surges on the telephone line, we recommend that nothing be connected to this pin.
24	Ring	<p>The Ring and Tip signals provide modem the connection to the telephone line. FCC Part 68 Rules require a 1500 volt isolation barrier between the telephone line and all other circuits. This isolation must be preserved throughout the system.</p> <p>UL60950 requires minimum creepage and clearances distances be maintained between the Tip and Ring traces and all other circuits. Clearance is the shortest distance between conductive</p>

NOTE: Although the XE2400G is a 3.3 volt device all serial inputs are 5 volt tolerant.

XE2400G Soldering Instructions

The XE2400G is subject to damage if overexposed to heat during solder reflow operations. Following the soldering instructions below will ensure that the process of soldering the module to the board does not damage the modem. The XE2400G must not be exposed to direct Infrared (IR) heating. If your process includes direct IR heating, you must shield the XE2400G from the infrared rays.

Maximum Temperature	220° C
Maximum Time at 220° C	20 Seconds
Maximum Time above Eutectic (180° C)	90 Seconds
Maximum Preheat Dwell Time	180 Seconds

Maximum Recommended Solder Temperature Profile

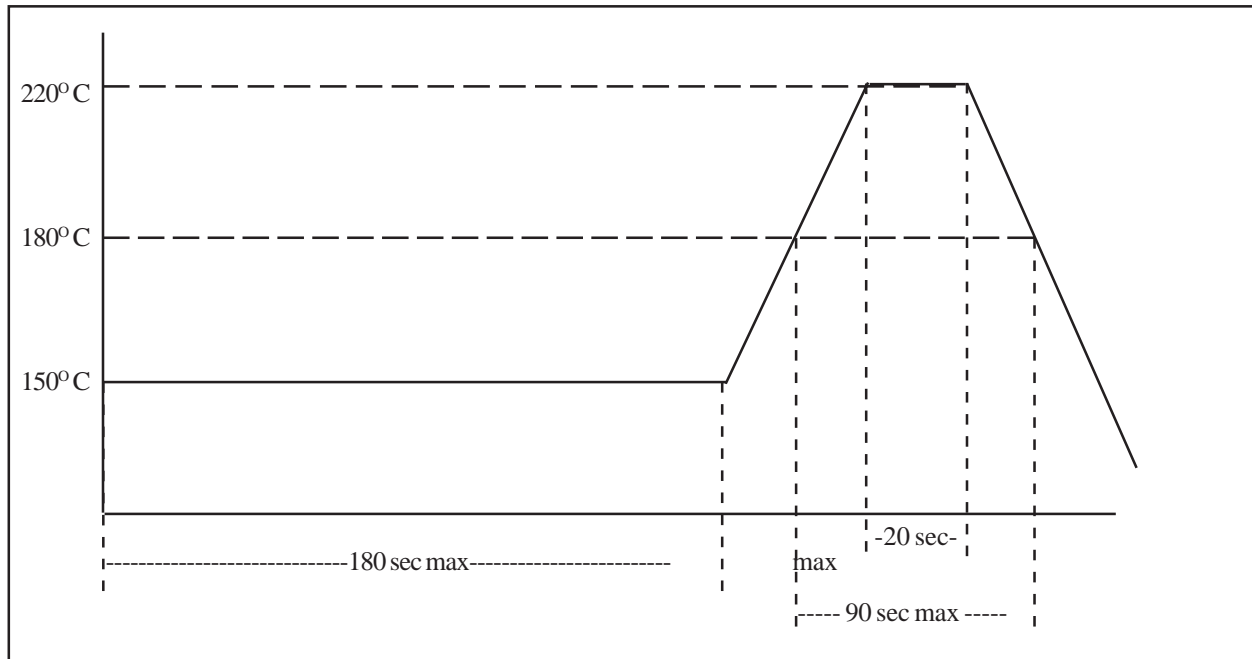

XE2400G Electrical Specifications

Parameter	Min	Typ	Max	Units	Comments
VCC	3.0	3.3	3.6	Volts	
ICC		80	85	ma	On Line
Ring Voltage Detected	26		150	VRMS	Type B Ringer
Ring Frequency Detected	15		68	Hz	Type B Ringer
Telephone Loop Current	16	40	120	ma	
Line Impedance		600		Ohms	
Data Transmit level		-12.0	-9.0	dBm	
DTMF Transmit Level		-2.5	0	dBm	Avg over 3 second interval
Voh	2.4		5.0	Volts	
Vol			0.4	Volts	
Vih	2.0		5.0	Volts	
Vil	-0.3		0.8	Volts	

XE2400G ABSOLUTE MAXIMUM RATINGS

VCC	4.1 Volts
Storage Temperature	-25° C to +85° C
¹ Maximum Operating Temperature Range	0° C to +70° C
Maximum Time Above Eutectic (183° C)	90 seconds
Preheat Dwell Time	120 to 180 seconds
¹ The XE2400G can be ordered with an Operating Temperature of -40° C to +85° C at extra cost. Order XE2400G-ITR or to specify Industrial Temperature Range (ITR).	

XE2400G Typical Connection Diagram

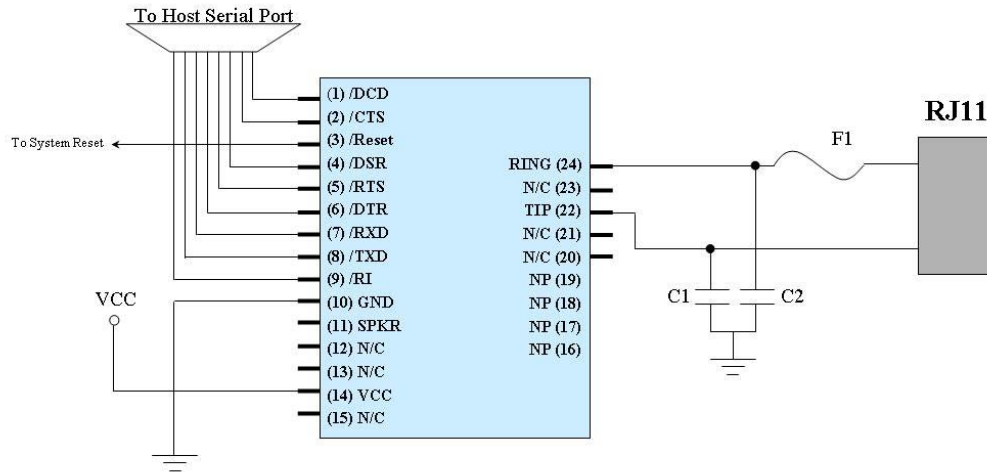

Parts List for XE2400G Typical Connection Diagram

Reference Designation	Qty	Description
C1, C2	2	Cap. 680 pfd, Y2
F1	1	PTC, TRF600-150

Notes:

- Capacitors, C1 and C2, may be required for EMI filtering in your system. Without these components you may experience unintended radiation when the telephone cable is attached. C1 and C2 are high-voltage capacitors. We recommend the Novocap ES2211N681K502NXTM.. This 680 pfd, 5000 volt capacitor will direct the high frequency harmonics to the system ground.
- F1 is a positive thermal coefficient (PTC) device which protects the modem from excessive current flow. These devices are required for your system to pass UL60950. Fuses may be used in place of the PTC's

Application Note: Using a 68-Pin PLCC Socket

The XE2400G can be inserted into a socket for a 68-pin PLCC device. The HyPLCC package uses only 20 pins; 15 on one side and 5 on the opposite side. Alignment within the socket is critical for all pins of the XE2400G to make contact with the appropriate pins of the PLCC socket. The drawing below illustrates how the XE2400G fits into the 68-pin PLCC socket. Emulation Technology's S-SMT-17-068-A socket is representative of sockets that can be used with the XE2400G.

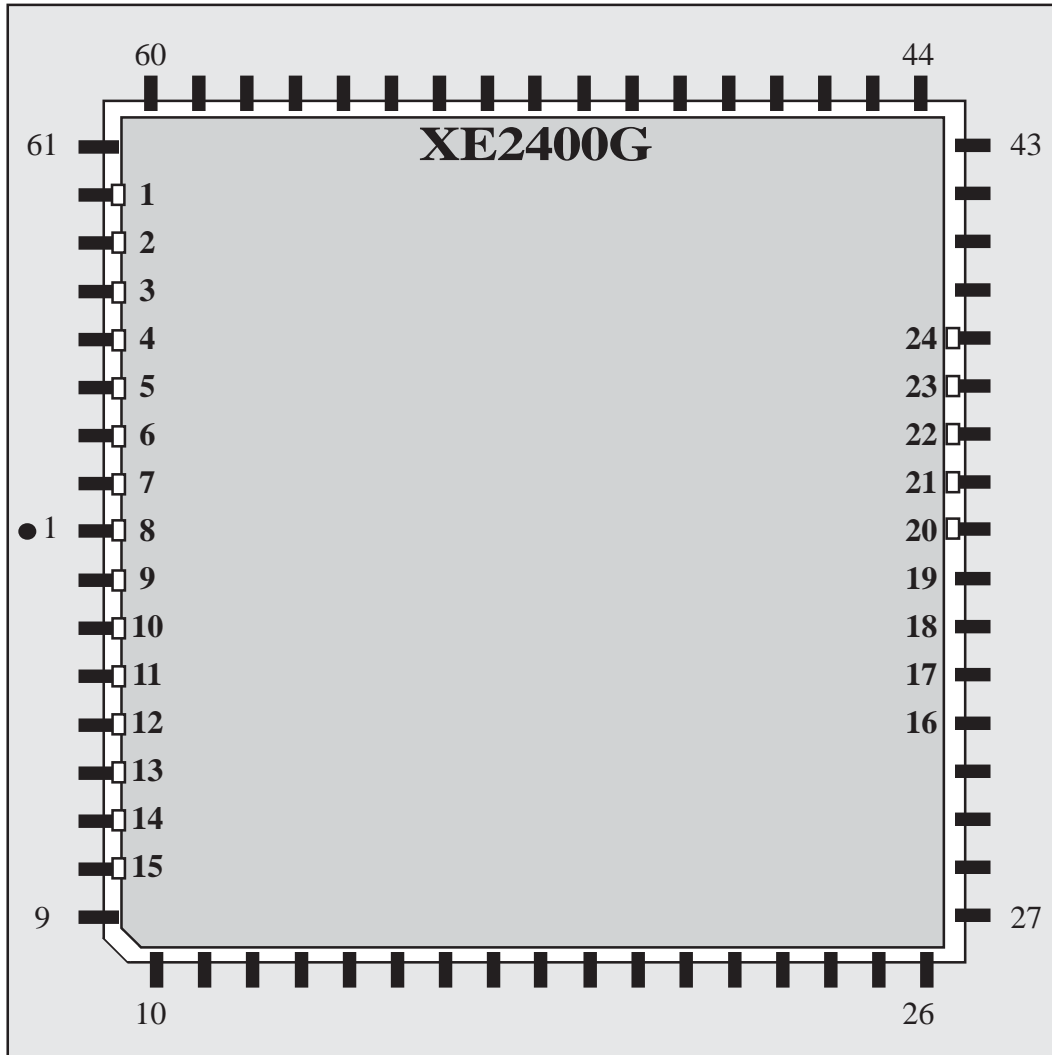

XE2400G Connection Data

The XE2400G reports data on the current connection in response to the AT+I1 command. Because many of the reported parameters require an active connection, this command is best utilized from the on-line command mode accessed with the escape sequence. The items shown in italics are only valid during an active call.

The Connection Report is presented in two pages. The first page will be displayed on receipt of the AT+I1 command. To move to the second page of the report hit any key. The table below describes the information provided in the Connection Report.

REPORTED ITEM	DESCRIPTION
1 Last Connection	Not Used
2 Initial Transmit Carrier Rate	Upstream data rate first negotiated on last connection
3 Initial Receive Carrier Rate	Downstream data rate first negotiated on last connection
4 Final Transmit Carrier Rate	Upstream data rate at the end of the last connection
5 Final Receive Carrier Rate	Downstream data rate at the end of the last connection
6 Protocol Negotiation Result	Reports the error correction protocol negotiated on last connection; values include LAPM/SREC, LAPM, MNP, and none.
7 Data Compression Result	Reports Link data compression protocol negotiated on last connection; values include LAPM, MNP, V.42bis, V.44 and none.
8 <i>Noise Level</i>	Reports the estimated noise level in the modem signal.
9 <i>Receive Signal Power Level</i>	Reports the approximate level of the incoming modem signal.
10 <i>Transmit Signal Power Level</i>	Reports the level of the outgoing modem signal.
11 <i>Round Trip Delay</i>	Reports how many milliseconds for the signal to be transmitted and returned.
12 <i>Near Echo level</i>	Not Used
13 <i>Far Echo Level</i>	Not Used
14 <i>Transmit Frame Count</i>	Reports the total number of LAPM frames transmitted thus far during the call.
15 <i>Transmit Frame Error Count</i>	Reports the number of transmitted frames rejected during the current call.
16 <i>Receive Frame Count</i>	Reports the total number of LAPM frames received thus far during the call.
17 <i>Transmit Frame Error Count</i>	Reports the number of received frames rejected during the current call.
18 <i>Retrain by Local Modem</i>	Reports the number of retrain and rate renegotiations requested by the local modem.
19 <i>Retrain by Remote Modem</i>	Reports the number of retrain and rate renegotiations requested by the remote modem.
20 <i>Local Rate Renegotiation</i>	Reports the number of rate renegotiations requested by the local modem.
21 <i>Remote Rate Renegotiation</i>	Reports the number of rate renegotiations requested by the remote modem.
22 Call Termination Cause	Reports the reason for termination of the last call; 0 indicates disconnect by local modem command, 1 indicates loss of received modem carrier, 2 indicates a failed call attempt, and 4 indicates a protocol failure.
23 Not Used	
24 Not Used	
25 Not Used	
26 Not Used	

XE2400G AT Commands

The XE2400 uses "AT" commands for configuration and control. This section describes the AT command format and lists the commands, registers and result codes.

Command Mode: The XE2400G enters command mode on power-up, reset, a lost connection, or receipt of the escape code. In command mode the modem accepts commands from the host on transmit data. Appropriate result codes are returned on received data.

Note: For backward compatibility some functions are controlled by more than one command. In these instances the last command issued determines the function setting.

Command Line Format

AT commands follow a strict format. Each command line, except A/, begins with the prefix AT. The "A" and "T" may be both upper case or both lower case but cannot be of different cases. The modem determines data rate of the host equipment by measuring the width of the incoming bits of the "A" and "T."

Multiple commands may be combined into a single command line of up to 40 characters. Commands are executed in the sequence they appear upon receipt of a carriage return. Spaces inserted into the command line are not placed in the buffer.

The command line can be edited with a backspace before it is executed. The backspace erases the previous character in the command line. Register S5 allows the user to select a character other than backspace to edit the command line.

If the command buffer overflows, the modem issues an "ERROR" result code, and the command line is not executed. Register S3 allows the user to select a character other than a carriage return to terminate the command line.

Re-Execute Last Command - The A/ command causes the modem to re-execute the last command line. This is the only command which does not require the "AT" prefix.

Omitted Parameters - Most commands include a parameter which determines how the functions will be set. When the command parameter is omitted from the command string, it is assumed to be a 0.

Escape Characters - A 3 character escape sequence may be entered to switch the modem into command mode while on line. The escape character, set by Register S2, must be entered 3 times in succession to execute the escape. An AT command must then be entered within the period defined by S12 to enter command mode. The default escape sequence is "+++."

Result Codes - The modem issues a result code after each action. Result codes may be sent as full words, one or two digit numeric codes, or may be disabled all together. Each result code ends with a carriage return when numeric result codes are chosen. When full word result codes are chosen, a Line Feed and Carriage Return precede and follow each result code.

XE2400G AT Commands

An asterisk indicates the factory default

A - Answer Command - Causes the modem to immediately go off-hook and attempt to a connection

D - Dial Command - Causes the modem to go off-hook and dial. Below are the characters accepted in the dialing string.

- 0-9, A-D, #, * = Dialing Digits
- L = Redial Last Number Dialed
- P = Pulse dial
- S=n = Dial number stored in location n
- T = Tone dial
- W = Wait for dial tone
- , = Pause for the duration of S8
- ! = Switch hook flash
- ; = Return to the command state

En - Command Echo - Determines if the modem returns the commands received from the host.

- n=0 Do not echo commands
- n=1 Enable command echo *

Hn - Switch Hook Control - Controls the connection to the telephone line.

- n=0 Switch hook relay opens
- n=1 Switch hook relay closes

In - Modem Identification - Provides product data..

- n=0 Modem identity
- n=1 ROM Checksum
- n=2 Verify Checksum,
- n=3 same as n=0
- n=4 Data Pump Firmware Version
- n=5 Code Version
- n=9 Country ID
- n=11 Connection Data

Ln - Speaker Volume - Selects level of speaker output.

- n=0,1 Low Volume
- n=2 Moderate Volume *
- n=3 High Volume

Mn - Speaker Activity - Determines when the speaker will be active.

- n=0 Speaker off
- n=1 Speaker on until carrier received *
- n=2 Speaker remains on
- n=3 Speaker on until DCD active

Nn - Link Negotiations - Selects how Register S37 will be used to set the link negotiations

- n=0 Connect only at the speed selected by S37
- n=1 Begin negotiations at the selected speed but allow fallback *

On - On Line - Puts the modem back into data mode from the on-line command mode.

- n=0 Return On Line with no retrain *
- n=1 Initiate retrain while returning On line.

Qn - Responses - Determines if the modem will send responses to the host.

- n=0 Send responses *
- n=1 No Responses

Sr? - Interrogate Register - Read register value

Sr=n - Set Register Value - Set register value.

Vn - Result Codes - Sets result code type

- n=0 Numeric Result Codes
- n=1 English Word Result Codes*

Wn - Expanded Result Codes - Adds protocol messages to the modem Connect responses.

- n=0 Report DTE Receive Speed
- n=1 Report DTE Speed and protocol type
- n=2 Report DCE Speed and protocol type *

XE2400G AT Commands

Xn - Result Code Set - Sets modem responses

- n=0 Responses 0-4
- n=1 Responses 0-5 & 10
- n=2 Responses 0-6 & 10
- n=3 Responses 0-5, 7 & 10
- n=4 Responses 0-8 & 10*
- n=5 All Responses
- n=6 All Responses
- n=7 All Responses but extended result codes

Z - Reset - Causes an immediate modem soft reset and reconfigures the modem to the stored values

&Cn - Data Carrier Detect Operation - Determines how the modem will present /DCD.

- n=0 /DCD forced active at all times
- n=1 /DCD indicates modem carrier signal state *

&Dn - Data Terminal Ready selects how the modem will react to the removal of /DTR from the host.

- n=0 Modem ignores status of /DTR
- n=1 If /DTR is removed with the modem on line, the modem enters on-line command mode
- n=2 /DTR must be active to maintain link *

&F - Restore Factory Configuration - Returns configuration to its factory settings.

&Kn - Local Flow Control - Determines the operation of flow control between the modem and local host.

- n=0 No Flow Control
- n=3 RTS/CTS (hardware) Flow Control *
- n=4 XON/XOFF (software) Flow Control

&Sn - Data Set Ready - Determines how the modem will present /DSR to the host.

- n=0 Force /DSR active *
- n=1 /DSR Indicates the modem's readiness to communicate

&Tn - Modem Test Modes - Control diagnostics

- n=0 Terminate Test in Progress
- n=1 Local Analog Loopback test
- n=3 Local Digital Loopback test

&V - View Active Configuration - Presents current modem configuration information

&W - Store Active Configuration - Places the current configuration into the selected memory location where it can be recalled on a soft reset.

&Zx=n - Store Number n in Location "x" - Permits placement of a telephone number in the selected memory location. Dialing the stored number is accomplished with the s=n dial modifier where n is the memory location of the stored number.

- x=0 Location 0
- x=1 Location 1
- x=2 Location 2

\Gn - In Band Flow Control - Determines how the modem handles received XON and XOFF flow control characters.

- n=0 Act on received XON and XOFF characters
- n=1 Pass XON/XOFF characters in data stream

\Kn - Break Response in Data Mode Determines how the modem will handle an received break signal.

- n=0 Enter on-line command mode, do not transmit break
- n=1 Clear data buffers, transmit break
- n=2 same as n=0
- n=3 Immediately transmit break
- n=4 same as n=0
- n=5 Transmit nondestructive break in sequence with data

\N - Error Control Mode - Selects which protocols will be used during data connections.

- n=0 Buffer Data, No Error Control
- n=1 Direct mode, No Error Control, No buffered data
- n=2 MNP Error Correction required
- n=3 Auto Error Correction *
- n=4 V.42 Required
- n=5 same as n=3
- n=7 same as n=3

XE2400G AT Commands

\Qn - Local Flow Control - Sets the flow control used to regulate data between the modem and local host.

- n=0 Disabled
- n=1 XON/XOFF (Software)
- n=3 RTS/CTS (Hardware) *

\Tn - Inactivity Timer - Sets the time the modem waits before disconnecting due to inactivity

- n=0 Timer disabled *
- n=1-255 Inactivity Timer in minutes the modem

\Xn - Software Flow Control Pass Through - Determines how the modem will process received XON and XOFF characters.

- n=0 Process XON and XOFF characters locally *
- n=1 Pass XON and XOFF characters to the remote modem

%Cn - Data Compression Control - Determines if Data Compression can be negotiated.

- n=0 Data Compression Disabled
- n=1 Data Compression Permitted *

+DCS=a,b - Select Data Compression Type - Selects the type of data compression to be used

- a - V.42bis
 - 0 = Disabled
 - 1 = Enabled *
- b - V.44
 - 0 - Disabled
 - 1 - Enabled *

+DR=a - Select Data Compression Report Type - Determines if a response will be issued to report the Data Compression status

- a - Data Compression Report
 - 0 = Disabled *
 - 1 = Enabled

+ER=a - Select Error Correction Report Type - Determines if the Error Control status of the connection will be reported.

- a - Error Correction Report
 - 0 = Disabled *
 - 1 = Enabled

+GCI = a Country Selection (Hex Format code) - Chooses the modem's country configuration. The country configuration is always stored in nonvolatile memory.

a - Country Code

- 00 = Japan
- 04 = Germany
- 09 = Australia
- 0A = Austria
- 0F = Belgium
- 20 = Canada
- 26 = People's Republic of China
- 31 = Denmark
- 3C = Finland
- 3D = France
- 42 = Germany
- 46 = Greece
- 50 = Hong Kong
- 51 = Hungary
- 53 = India
- 54 = Indonesia
- 57 = Ireland
- 59 = Italy
- 61 = Korea
- 6C = Malaysia
- 72 = Europe
- 73 = Mexico
- 7B = Netherlands
- 7E = New Zealand
- 82 = Norway
- 89 = Philippines
- 8B = Portugal
- 9C = Singapore
- 9F = South Africa
- A0 = Spain
- A5 = Sweden
- A6 = Switzerland
- A9 = Thailand
- AE = Turkey
- B4 = United Kingdom
- B5 = United States
- BC = Vietnam

XE2400G AT Commands

+IFC = a,b Local Flow Control - Selects the flow control settings for the modem.

a - DTE control of data from DCE

0= No Flow Control

1= XON/XOFF (Software Flow Control)

2= RTS/CTS (Hardware Flow Control) *

b - DCE control of data from DTE

0= No Flow Control

1= XON/XOFF (Software Flow Control)

2= RTS/CTS (Hardware Flow Control) *

+IPR=a - Fix Serial Data Rate - Sets the speed of the serial interface to a predetermined rate.

a - Data Rate Setting

0	=	Automatic rate detection
110	=	100 bps
300	=	300 bps
600	=	600 bps
1200	=	1200 bps
2400	=	2400 bps
4800	=	4800 bps
9600	=	9600 bps
14400	=	14,400 bps
19200	=	19,200 bps
38400	=	38,400 bps
57600	=	57,600 bps
115200	=	115,200 bps

XE2400G RESPONSES

<u>Digits</u>	<u>Verbose</u>	<u>Description</u>
0	OK	Command Successful
1	CONNECT	300 bps or higher connection
2	RING	Ring signal detected
3	NO CARRIER	Carrier not detected
4	ERROR	Error in command line
5	CONNECT 1200	1200 bps Connection
6	NO DIAL TONE	No dial tone detected
7	BUSY	Busy signal detected
8	NO ANSWER	Remote does not answer
9	RINGING	Ringback signal detected
10	CONNECT 2400	2400 bps Connection
30	CIDM	Caller ID Detected
31	FLASH	Hookswitch Flash detected
32	STAS	UK Caller ID Alert detected
33	X	Over current Condition
40	BLACKLIST FULL	The buffer for storing blacklisted numbers is full
41	BLACKLISTED	Attempted Number is Blacklisted
42	NOLINE	No Telephone line is connected to the modem
43	LINE IN USE	The attached Telephone line is in use
70	PROTOCOL: NONE	No Link Protocol negotiated
75	CONNECT 75	75 bps connection
77	PROTOCOL V.42	V.42 error correction protocol negotiated
79	PROTOCOL V.42bis	V.42bis data compression protocol negotiated
80	PROTOCOL: ALTERNATE, + CLASS 2	MNP2 error correction negotiated
81	PROTOCOL: ALTERNATE, + CLASS 3	MNP3 error correction negotiated
82	PROTOCOL: ALTERNATE, + CLASS 4	MNP4 error correction negotiated
102	UN-OBTAINABLE NUMBER	DTMF Dial attempt on Pulse only Line

XE2400G REGISTER SETTINGS

- S0 Answer on nth Ring:** S0 sets the modem to automatically answer on the nth ring. Setting S0 to 0 disables automatic answer.
Range: 0 to 255
Units Rings
Default 0
- S1 Ring Count:** S1 is a read-only register showing the number of rings detected. If no ring is detected within 8 seconds, S1 is reset.
Range: 0 to 255
Units Rings
Default 0
- S2 Escape Character:** S2 sets the ASCII escape character. Values of 0-127 select valid characters; values from 128 to 255 disable the escape sequence.
Range: 0 to 255
Units ASCII Character
Default 43 (+)
- S3 Line Termination Character:** S3 determines the ASCII character which will terminate commands and modem responses.
Range: 0 to 127
Units ASCII Character
Default 13 (Carriage Return)
- S4 Line Feed Character:** S4 sets the ASCII character to act as a line feed character in modem responses.
Range: 0 to 127
Units ASCII Character
Default 10 (Line Feed)
- S5 Backspace Character:** S5 defines the ASCII character used as a backspace to edit the command line.
Range: 0 to 127
Units ASCII Character
Default 8 (Back Space)
- S6 Dial Tone Wait Time:** S6 determines how long the modem waits for dial tone before dialing. The Dial Tone Wait Time cannot be less than two seconds.
Range: 0 to 255
Units Seconds
Default 3
- S7 Wait for Carrier after Dialing:** S7 determines how long the modem waits for a valid carrier signal after dialing.
Range: 0 to 255
Units Seconds
Default 60
- S8 Comma Pause Time:** S8 defines the duration of the pause initiated by a comma in the dialing string. The pause is generally used when waiting for a second dial tone.
Range: 0 to 255
Units Seconds
Default 2
- S10 Carrier Off Disconnect Delay:** S10 selects how long carrier must be lost before the modem disconnects.
Range: 1 to 255
Units 0.1 Seconds
Default 20
- S11 DTMF Dialing Speed:** S11 determines the duration and spacing in milliseconds of DTMF tones
Range: 50 to 150
Units milliseconds
Default 95
- S12 Escape Code Guard Timer:** S12 sets the escape sequence guard timer. If characters are received before or after the escape sequence, within the guard timer, the modem aborts the escape and remains in data mode.
Range: 10 to 255
Units 0.02 Seconds
Default 50
- S14 Wait for Dial Tone Delay:** S14 determines how long the modem will wait for dial tone when the W dial modifier is used.
Range: 0 to 255
Units Seconds
Default 8

XE2400G REGISTER SETTINGS

- S28 **V.34 Modulation:** S28 determines if V.34 modulation can be used.
S28=0 Disabled
S28=1 Enabled
Default: 1
- S30 **Disconnect Inactivity Timer:** S30 sets how long the modem remains on line with no data flowing. A zero prevents the modem from disconnecting due to inactivity.
Range: 0-255
Units: Minutes
Default: 0
- S35 **Calling Tone:** S35 determines if Calling Tone will be present on a data call.
S35=0 Disabled
S35=1 Enabled
Default: 1
- S36 **Response to LAPM Negotiation failure:** S36 determines the action taken by the modem if the selected error correction negotiations are unsuccessful.
S36= 0 Disconnect
S36= 1 Maintain link with no error correction
S36= 2 Disconnect
S36= 3 Maintain link with no error correction
S36= 4 Attempt MNP; disconnect on MNP failure
S36= 5 Attempt MNP; maintain link with no error correction on MNP failure
S36= 6 Attempt MNP; disconnect on MNP failure
S36= 7 Attempt MNP; maintain link with no error correction on MNP failure
Default: 7
- S37 **Line Data Rate:** S37 sets the maximum line data rate that can be negotiated
0 = Automatic Negotiation
2 = V.23, 1200/75 bps
3 = 300 bps
5 = 1200 bps
6 = 2400 bps *
- S48 **LAPM Error Control** - S48 allows LAPM Error Control to be enabled or disabled.
S48= 128 LAPM Disabled
S48=7 LAPM Enabled
Default: 7

FCC Instructions

The XE2400G complies with Part 68 of the FCC Rules and Regulations. With each device shipped, there is a label which contains the FCC Registration Number. The FCC Registration number incorporates the Model Number, Manufacturer Identifier, Product Type identifier and Ringer Equivalence Number (REN) for this product. You must, upon request, provide this information to your telephone company. The format of the FCC Registration Number is shown below.

US: DWEMM01BXE2400G (pending)

The mounting of this device in the final assembly must be made in such a manner as to preserve the high voltage protection between the TIP/RING Connection and the rest of the system. Typically, this may be accomplished by maintaining a minimum spacing 100 mils between the TIP/RING Traces to the RJ-11C Jack and low voltage portion of the system. No additional circuitry may be attached between TIP/RING and the telephone line connection, unless specifically allowed in the rules.

The REN is useful to determine the quantity of devices you may connect to a telephone line and still have all of these devices ring when the number is called. In most, but not all areas, the sum of the RENs of all devices connected to one line should not exceed five (5.0). To be certain of the number of devices you may connect to the line, as determined by the REN, you should contact the local telephone company to determine the maximum REN for you calling area.

If your system causes harm to the telephone network, the telephone company may discontinue service temporarily. If possible, they will notify you in advance. If advance notification is not practical, you will be notified as soon as possible.

Your telephone company may make changes in its facilities, equipment, operations or procedures that could affect proper functioning of your equipment. If they do, you will be notified in advance to give you an opportunity to maintain uninterrupted telephone service.

If you experience trouble with this device, please contact XECOM at (408) 942-2200 for information on obtaining service or repairs. The telephone company may ask you to disconnect this device from the network until the problem has been corrected or until you are sure that the device is not malfunctioning.

Terms of Sale

Devices sold by XECOM are covered by the warranty provisions appearing in its Terms of Sale only. XECOM makes no warranty, express, statutory, implied, or by description regarding the information set forth herein, or regarding the freedom of the described devices from patent infringement. XECOM makes no warranty of merchantability or fitness for any purposes. XECOM reserves the right to discontinue production and change specifications and prices at any time and without notice. This product is intended for use in normal commercial applications. Applications requiring extended temperature range, unusual environmental requirements, or high reliability applications, such as military, medical life-support or life-sustaining equipment, are specifically not recommended without additional processing and authorization by XECOM for such application.

Xecom assumes no responsibility for the use of any circuitry other than circuitry embodied in a Xecom product. No other circuits, patents, or licenses are implied.

Life Support Policy

Xecom's products are not authorized for use as Critical Components in Life Support Devices or Systems.

Life Support Devices or Systems are devices or systems which, (a) are intended for surgical implant into the body, or (b) support or sustain life, and whose failure to perform, when properly used in accordance with instructions provided in the labeling, can be reasonably expected to result in significant injury to the user.

A Critical Component is any component of a life support device or system whose failure to perform can be reasonably expected to cause failure of the life support device or system, or to affect its safety or effectiveness.

Copyright, Xecom © 2007

While Xecom, Inc. has made every effort to ensure that the information presented here is accurate, Xecom will not be liable for any damages arising from errors or omission of fact. Xecom reserves the right to modify specifications and/or prices without notice. Product mentioned herein are used for identification purposes only and may be trademarks and/or registered trademarks of their respective companies.

The Xecom logo consists of the word "xecom" in a bold, lowercase, sans-serif font, with a registered trademark symbol (®) to the upper right. The text is white and set against a solid black rectangular background.

Xecom Incorporated
374 Turquoise Street, Milpitas, CA 95035
Ph:408-942-2000 Fax:408-942-1346 E-Mail: info@xecom.com