

CH1788

Surface Mount PLCC 2400bps Modem

INTRODUCTION

The CH1788 modem has the smallest footprint and lowest profile of any commercially available full function, FCC Part 68 approved 2400bps modem. Utilizing a 68 pin PLCC form factor and requiring a minimum amount of PCB space (0.95"x0.95"x0.255"), the CH1788 affords the design engineer maximum flexibility. The CH1788 provides two external interfaces: a ITU-T V.24 standard 5 volt serial interface for routing directly to a UART; and a TIP and RING interface for connection to the PSTN telephone line. The CH1788 is compatible with available industry communication software or may be controlled with software commands via an embedded microcontroller.

The CH1788 modem supports asynchronous operation at 2400bps, 1200bps, and 300bps to both Bell and ITU-T standards. Each device is FCC approved and Canadian DOT approvable. An FCC label is supplied. The CH1788 also meets UL 1950 Edition 3 requirements.

The CH1788 family of modems operate from a 5 volt DC supply (3.3 volt devices are available by special order). The combination of low power operation, zero power standby mode and small form factor make the CH1788 an ideal choice for portable equipment

- CS-03 Industry Canada registered.
- UL 1950 and CSA C22.2 950 Listed.
- AT Command structure.
- Speed buffered operation at: 9600, 2400, 1200 and 300bps.
- Call progress tone detection.
- Caller ID information.
- Line In Use and Priority Pick Up 911 feature support with external circuitry.
- DTMF generation and detection resident on CH1788.
- 5 volt operation/ 3.3 volt operation available.
- Low power operation with automatic reduced power idle and zero power standby modes.
- Low profile PLCC surface mount packaging; fits standard 68 pin PLCC socket.
- Size: 0.95" x 0.95" x 0.255"(nominal).

CH1788 FAMILY

CH1788	Operating Temperature: 0°C to +70°C
CH1788ET	Operating Temperature: -40°C to +85°C
CH1788-3	3.3 volt Operation Operating Temperature: 0°C to +70°C
CH1788-3ET	3.3 volt Operation Operating Temperature: -40°C to +85°C

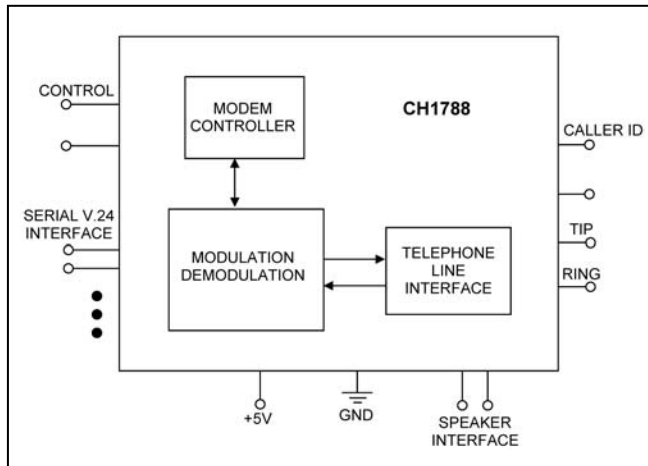

applications.

Figure 1. Functional Block Diagram of CH1788.

FEATURES

- Supports data rate standards, ITU-T V.22bis, V.22, Bell 212, and Bell 103, Bell 202, V.23.
- Fast connect handshaking.
- FCC Part 68 approved.

DESCRIPTION OF FUNCTIONAL BLOCKS AND DISCUSSION OF BASIC OPERATIONS

Figure 1 contains a functional block drawing of the CH1788. The CH1788 is a highly integrated, full-function modem, comprised of a modulator/demodulator, controller, and an FCC Part 68 approved telephone line interface.

Modulation/Demodulation and Modem Controller. This function is provided by a monolithic modem integrated circuit. The function is performed to ITU-T standards thereby making the CH1788 compatible

with all modems. The ability to execute AT commands is consistent with industry standards.

Telephone Line Interface or DAA. The CH1788 is designed to meet 1500VAC RMS isolation and provide 2122V peak surge protection. Consequently, the CH1788 satisfies North American and some international requirements. Note that supplemental protection is required for FCC Part 68 conveyed approval (see Figure 3 of this document). This supplemental protection also improves field reliability and facilitates FCC part 15 approval.

SUPPORTED FEATURES

AT Command Set. Internal to the CH1788 is an AT command interpreter. AT commands and their associated S-registers provide macro functionality. These commands are summarized in this document and are detailed in Cermetek publication [CH1788 AT Command and S-Register Reference Guide](#).

The CH1788 supports command concatenation. A maximum of 63 characters (excluding AT) may be included on each command line. S-registers provide added programmability by allowing key parameters to be configured for a specific application.

Serial Host Interface. The serial interface is a standard TTL V.24 5V DC interface. It is functionally similar to an RS232 interface.

IMPORTANT NOTE

Do not use RS232 interface voltage levels on the serial pins. Damage may result. Adhere to the TTL V.24 5V DC interface standard. See Schematic 7 for a suggested circuit to interface RS-232 logic to the CH1788 TTL V.24 logic.

Command Characters. Each data byte or command character consists of ten bits: 1 start bit, 1 stop bit, and eight data bits. The data bits can be either eight bits with no parity or seven odd or even with 1 parity bit. The start bit is LOW going. RXD and TXD data is non-inverted. See the pin descriptions in Table 2.

Data Encoding. The data encoding is user configurable. The ATB command sets the decoding. The following ITU-T standards are supported: V.22bis, V.22, Bell 212A, 103, Bell 202 or V.23.

Speed Buffered Mode. Speed Buffering allows the serial data interface or DTE speed (i.e., the speed between the host microcontroller and the CH1788) to be fixed regardless of the connect or DCE speed (i.e., the speed between the CH1788 and the remote modem).

The option exists to disable Speed Buffering by using the ATY0 command. If Speed Buffering is disabled,

the data connection DCE speed will be equivalent to the originating modems serial connection DTE speed. In other words, disabling Speed Buffering forces the answering modem to connect with a DCE speed equivalent to the serial DTE speed of the originating modem.

Data Transmission Speed. The CH1788 allows the DTE speed to be set to 300, 1200, 2400, or 9600bps. The DCE speed can be set to 2400, 1200, or 300bps. A connect message will appear on RXD indicating the connected data rate.

General Operation. By definition, the originating modem initiates the PSTN connection and the answering modem accepts the incoming call. The connectivity speed (i.e., DCE speed) is determined by the originating modem.

The originating modem's DTE speed is established, in turn, with an initializing AT command issued by the application's host controller. Speed Buffering allows the CH1788 to communicate with the host controller at a DTE speed that is greater than the connect DCE speed.

Assuming that the default configuration of the CH1788 has not been modified with the ATB or ATY0 commands, the answering modem will attempt to connect to the originating modem at the highest possible data rate supported by the originating modem. The connection rate can be less than the maximum of 2400bps, for example, if the PSTN line is impaired in some way.

By default upon power up, the CH1788 DTE speed is set to 9600bps and Speed Buffering is enabled.

Typical Implementation. In a typical implementation, the CH1788 has a DTE speed of 9600bps and will connect to the remote modem at a DCE speed of 2400bps. Speed Buffering allows the CH1788 to negotiate the DCE speed independent of the DTE speed. Data transfer to the host will be at the DTE Speed Buffered rate of 9600bps. In this case, flow control is not required.

It is possible for the DTE speed to be slower than the DCE speed. For example, a serial interface DTE speed of 1200 bps and a data rate DCE speed of 2400 bps. In this case, flow control must be employed by the host to prevent buffer overflow and lost data.

POWER DOWN

The CH1788 has two power down modes: idle power standby and zero power standby.

Idle Power Standby. In idle power standby mode is enabled by executing **ATS73+2** in the set up string. Power is switched off automatically by the CH1788 after a period of no activity and is restored automatically by the CH1788 when activity is again detected. Activity is defined as a change of status on DTR, TXD, RST or on any of the other input pins or an Incoming Ringing signal on TIP/RING. Idle power mode transitions are transparent to the user.

Zero Power Standby. In applications requiring near zero power during standby periods, the power may be switched completely off to the CH1788. This is done by issuing the **AT@Z** command or by toggling DTR after the **ATR5** command has been executed. Normal operation is resumed by performing a 50 msec (minimum) hardware reset on the RST pin.

RING INDICATION

The CH1788 produces a low going 80 msec pulse on the RI Pin when a valid Incoming Ring signal is detected. By default, a valid ring signal must fall within the 10-75 Hz range and have a cadence of 2 seconds on and 4 seconds off. Alternate frequency ranges and ring cadence's may be programmed.

CH1788 RESET

The CH1788 may be reset using any of the following methods. Delay sending commands to the CH1788 for a period of 500 msec after reset has been completed to allow the CH1788 time to properly reconfigure.

Hardware Reset. Upon power-up or when power cycling, the CH1788 will automatically generate an internal reset pulse. However, if the power supply comes up too slowly, or has a rise time greater than 50 msec, the internal reset detection circuitry may not generate the hardware reset.

RST Pin. Initiate a reset externally anytime after the power supply has stabilized by applying a 50 msec TTL high reset pulse to the RST pin.

Software Reset. Execute the **ATZ** command while in command mode.

DTR Pin. Toggle the DTR pin after executing the **ATR3** command while in command mode.

POWER SUPPLY

Although any standard 5 volt DC supply is acceptable, the user should be aware that during the course of normal operation the CH1788 decodes analog data signals from the PSTN line that are in the millivolt range. Steps must be taken by the user to insure that power supply noise on all supply lines,

including ground, does not exceed 50 mV peak to peak. Any frequency between 20 kHz and 150 kHz must be less than 500 micro volts peak. If necessary, use dedicated power and ground planes. Failure to provide such operating conditions could cause the CH1788 to malfunction or to function erratically.

Recommendation. To reduce the effects of supply noise, it is recommended that by-pass capacitors be placed on the power supply as close to the CH1788's supply input (i.e., Pin 20) as practical. A 10 μ F Tantalum capacitor in parallel with a 0.01 μ F ceramic is recommended.

DTMF TONE DETECTION

The CH1788 is capable of detecting DTMF tones without external hardware.

Setup. Detection will only occur when the CH1788 is Off-Hook and in the command mode.

DTMF Decoding. The **ATJ6** command enables DTMF decoding. Register S65 will contain the decoded DTMF result. The S65 register must be continuously interrogated by the host controller because the decoded DTMF decimal value is only present in S65 when the DTMF tones are present on the PSTN line.

The full range of decoded DTMF decimal values are listed in Table 1. If the S65 register contains zero, it indicates that no DTMF tones are present. Note, the S65 register will contain zero between DTMF tones.

Recommendation. Sample the S65 register at a rate at least twice (2X) the fastest DTMF tone periodic rate. DTMF tones typically have a cadence of 70 msec on and 70 msec off. In this case, the S65 register should be sampled at least every 35 msec.

Table 1. DTMF Tone Conversion.

DTMF TONE	DECIMAL VALUE
1	129
2	130
3	131
4	132
5	133
6	134
7	135
8	136
9	137
0	138
*	139
#	140
No Tone	0

DTMF TONE GENERATION

The CH1788 is capable of generating DTMF tones without external hardware. DTMF tone generation is useful for signaling and is supplemental to the DTMF dialing capability.

Setup. Generation will only occur when the CH1788 is Off-Hook, in the command mode and prior to carrier generation.

DTMF Encoding. By default, the CH1788 generates DTMF tones at a 70 msec on/off cycle. The cycle can be modified with register S11.

Issuing an **ATDT** command string with the desired DTMF digits and terminating the command string with a semicolon (;) will cause the CH1788 to immediately enter command mode after dialing. Alternatively, the command mode may be entered from the data mode by issuing the escape sequence (+++) to the CH1788.

Enter: **ATDT1234567890*#;<CR>**
 Result: Sends the DTMF tones and returns to command mode. DO not exceed 63 characters on the command line.

DTMF Tones may also be sent using external circuitry via the voice injection port. See Schematic 2.

CALLER ID

The CH1788 will detect Caller ID (i.e., CID) information. CID data, when supplied by the local telephone service provider, is present between the first and second ring signals. Valid CID data is preceded by the "CID" designation. This feature is enabled via register S95.

Setup. CID requires additional external circuitry. An RC network must be added to the CH1788 V+ and V- pins. See Schematic 4 for details. Register S95 must be set to 8 (the default value) to receive the CID information. Other caller ID options are available. See the details of register S95.

Operation. Using the circuit in Schematic 4, monitor the RI pin for the period between the first and second ring signal. The decoded CID data will appear on RXD.

LINE IN USE

The Line In Use (i.e., LIU) feature allows the CH1788 to signal the host when a shared PSTN line is in use. When in use, the LINE IN USE status message will appear on RXD and the CH1788 will NOT go Off-Hook. This feature is enabled via register S110.

Setup. The LIU feature requires additional external circuitry. See Schematic 5 and Schematic 6. Additionally, register S110 must be set to 243.

PARALLEL PICK-UP

The Parallel Pick-Up (i.e., PIU) feature allows the termination of a CH1788 modem call in progress, and then allows a standard phone instrument sharing the same PSTN line to seize the line and obtain a dial tone. When terminating the modem call, DCD will go high, if enabled. The PPU-V status message appears on RXD.

Setup. The Parallel Pick-Up feature requires external circuitry. See Schematic 5.

Operation. The Parallel Pick-Up circuit detects the incremental change in Off-Hook voltage on the PSTN line. If a parallel connected phone instrument is Off-Hook, the CH1788 will not attempt to go Off-Hook. If the CH1788 is already Off-Hook and a parallel connected phone instrument goes Off-Hook, the CH1788 will terminate the calling progress and allow the sharing device to seize the line.

Failure To Detect. The detection circuit in the CH1788 may not detect the Off-Hook condition for select phone instruments because some phone instruments may not change the Off-Hook voltage sufficiently to allow detection.

There is also the possibility that two devices going Off-Hook simultaneously may defeat the PPU detection circuitry.

Recommendation. To avoid a Failure To Detect condition, use of a prioritized scheme such as that employed in the 911 Priority Pick-Up application circuit described below is strongly suggested.

IMPORTANT NOTE

The Parallel Pick-Up feature should only be used in non-critical applications and never used as a substitute for the 911 Priority Pick-Up feature.

911 PRIORITY PICK-UP

The 911 Priority Pick-Up (i.e., 911 PPU) feature allows the CH1788 to give Off-Hook priority to any telephone sharing the PSTN line with the CH1788.

Setup. The 911 Priority Pick-Up feature requires external circuitry. See Schematic 6.

Operation. If a parallel connected phone instrument goes Off-Hook while the CH1788 is Off-Hook, the CH1788 will immediately disconnect to give priority to the phone instrument.

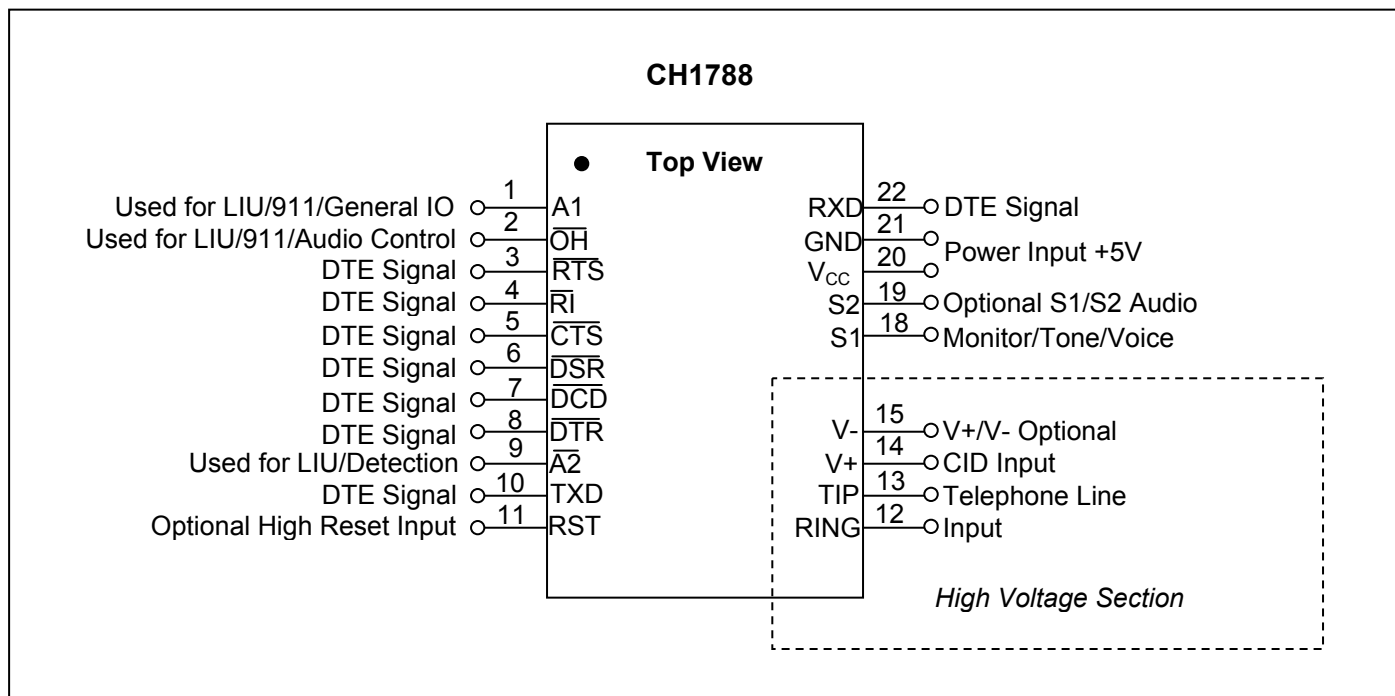

Figure 2. CH1788 Pin Configuration. See Table 2 for detailed Pin Descriptions.

Table 2. CH1788 Pin Descriptions.

PIN	NAME	TYPE	FUNCTION
1	A1	O	Optional Input. Active high. Used when implementing the 911 Priority Pick-Up circuit or the Line In Use circuit.
2	\overline{OH}	O	Off-Hook. Active low. \overline{OH} Indicates when the CH1788 is Off-Hook. Used in Line In Use, 911 Priority Pick-Up applications and for Audio Control.
3	\overline{RTS}	I	Request To Send. Active low. Used for optional flow control. Used in conjunction with the Clear to Send (CTS) pin as a handshaking signal. See the details of register S90.
4	\overline{RI}	O	Ring Indication. Active low. For each occurrence of a valid ring signal, this pin will pulse low for 70 ms. This output signal follows the frequency of the ringing signal and is typically in the 20 to 40 Hz range with a cadence of 2 seconds on with 4 seconds off.
5	\overline{CTS}	O	Clear to send. Active low. Used for optional flow control. Used in conjunction with the Request To Send (\overline{RTS}) pin as a handshaking signal.
6	\overline{DSR}	O	Data Set Ready. Active low. A low indicates that handshaking with the remote modem is in progress and/or the carrier of the remote modem has been detected and a valid connection is imminent as measured by DCD being active. This feature is enabled with the N command.
7	\overline{DCD}	O	Data Carrier Detect. Active low. This output must be enabled with the ATC1 command. When enabled, it will become active when both the originated and answering modems are connected and a data carrier has been detected.

NOTE: 1. All unused pins should be left unconnected when not required in a specific application, unless specifically directed otherwise.
 2. See DC characteristics before attempting to drive an LED directly from the output of any pin.

Table 2. CH1788 Pin Descriptions (Continued).

PIN	NAME	TYPE	FUNCTION
8	$\overline{\text{DTR}}$	I	Data Terminal Ready. Active low. The response to this input is controlled by the Rn command where n specifies the desired options and includes: returning the modem to the command state, hanging up the modem, resetting the modem, and placing the modem in zero power mode.
9	$\overline{\text{A2}}$	I	Optional Input. Active low. Used when implementing the Line In Use circuit.
10	TXD	I	Transmit Data. Serial transmit data input. Data starts with a high to low transition. Mark or binary 1 condition is indicated by HIGH.
11	RST	I	Reset. Active HIGH. This input must be asserted HIGH for at least 50 ms to reset the modem. The RST pin must be returned LOW for normal operation to commence. If a system reset is not available, let this pin float to enable the internal reset circuitry.
12	RING	I/O	Ring. Telephone connection requires an active public switched telephone line (PSTN) for normal operation. This line should be routed to the RJ-11C jack through the recommended protection circuitry.
13	TIP	I/O	TIP. Telephone connection requires an active public switched telephone line (PSTN) for normal operation. This line should be routed to the RJ-11C jack through the recommended protection circuitry.
14	V+	I	Caller ID. Used to connect an external RC network to enable caller ID operation. See the application circuit in the Schematic 4.
15	V-	I	Caller ID. Used to connect an external RC network to enable caller ID operation. See the application circuit in the Schematic 4.
18	S1	I/O	Audio Port. Optional audio port input. Allows the internal DAA to be shared with external voice, tone injection or call progress monitoring applications. See the application circuits in the Schematic 2 and 3. Note that the CH1788 is FCC approved for data applications only. Inclusion of voice or other audio functions may require additional certification by the FCC.
19	S2	I/O	Audio Port. Optional audio port input. Allows the internal DAA to be shared with external voice, tone injection or call progress monitoring applications. See the application circuits in the Schematic 2 and 3. Note that the CH1788 is FCC approved for data applications only. Inclusion of voice or other audio functions may require additional certification by the FCC.
20	V _{CC}	--	Power Supply. 5 Volt DC +/- 5%. Supply noise should be less than 50 mV _{pp} . Also available at for 3.3 volt DC operation, upon special request.
21	GND	-	Ground. Circuit ground. Use recommended bypass capacitors between GND and VCC.
22	RXD	O	Receive Data. Serial receive data output. Data starts with a high to low transition. Received mark or binary 1 condition is indicated by HIGH.
NOTE:			
1. All unused pins should be left unconnected when not required in a specific application, unless specifically directed otherwise.			
2. See DC characteristics before attempting to drive an LED directly from the output of any pin.			

IMPORTANT NOTE

The 911 PPU feature requires the CH1788 must be the first device on the installation's PSTN line. All other phone or higher priority instruments to be down the line from the CH1788.

CALL PROGRESS MONITORING

Call Progress Monitoring allows a call to be monitored during the dialing sequence. This feature becomes active when the CH1788 goes Off-Hook and automatically disables when DCD is detected. It is also inactive if a connection attempt should fail and the CH1788 goes back On-Hook. To enable this feature, the DCD line must be activated with the **ATC1** command.

Setup. This feature requires additional external circuitry. See Schematic 2. Although the circuit in Schematic 2 uses a variable resistor to adjust the speaker volume, a fixed value resistor may be substituted.

Alternate Setup. Control of the speaker can alternately be performed under command control. To implement this alternate control method, modify the circuit in Schematic 2 by connecting resistor R5 to A1 instead of DCD. This allows register S101 to be used to turn the speaker on or off. Set S101 to 1 to turn the circuit on, set S101 to 0 to turn the circuit off.

FAST CONNECT HANDSHAKING

The CH1788 supports a fast handshaking (often called "quick connect") feature.

Typically, the initial handshaking sequence for a V.90 modem (56Kbp) takes 20-30 seconds to complete. A standard 2400bps (V.22bis) modem connects in 4-8 seconds. With the Fast Connect feature enabled, the CH1788 will connect at 1200bps (Bell 212) in as little as 0.5 seconds. This feature will work with any compatible modem.

Setup: Originate Mode. The Fast Connect feature, when the CH1788 is in originate mode, is activated by using the following command setup string:

Enter: **ATFY0X4K0S30=\$10S89=\$40<CR>**
Result: **OK**

Setup: Answer Mode. The Fast Connect feature, when the CH1788 is in answer mode, is activated by using the following command setup string:

Enter: **ATL3<CR>**
Result: **OK**

IMPORTANT NOTE

The Fast Connect feature is operational only for DTE speeds of 1200bps (Bell 212).

LONG SPACE DISCONNECT

The long space disconnect signal is used to force the CH1788 to release the PSTN line and go back On-Hook.

Setup. To enable this feature, bit 7 of register S110 must be set to 1. See the details of register S110.

VOICE INJECTION

It is possible to share the CH1788's internal DAA with external applications. This allows one PSTN line to be shared between an external voice application and the CH1788 modem. This feature is controlled via register S101 when using the configuration in Schematic 3.

Setup. This feature requires additional external circuitry. See Schematic 3. This application implements Voice Injection via the S1 and S2 pins and requires a two to four wire converter and a relay circuit. Set S101 to 1 to activate Voice Inject and set S101 to 0 to deactivate Voice Inject.

Operation. The two to four wire converter circuit provides for simultaneous voice in and voice out (with respect to ground). This circuit must be capacitor coupled (i.e., C7) to the CH1788 and isolated from ground (i.e., C6). Voice/data switching is controlled by setting register S101 appropriately.

During Voice Injection, the voice signal must not exceed $2.187 V_{pp}$ (i.e., zero dB) per FCC maximum permissible limits. When sending data, the voice circuit must be fully disconnected from the line (i.e., Voice Inject deactivated) or data corruption will occur.

IMPORTANT NOTE

When utilizing the Voice Injection circuit, it is necessary to submit the end product containing the CH1788 Voice Injection feature to an FCC approved testing facility for re-approval of the end product per FCC Part 68 requirements.

MODEM CONTROL

The CH1788 may be controlled with ASCII AT commands sequences. The commands are sent to the CH1788 serially via the TXD pin. After execution of a received command string, the CH1788 returns a serial status message on RXD.

INITIALIZING THE MODEM

The CH1788 must be initialized before the CH1788 will recognize commands. Initialization is a two step activity consisting of:

- Table 4.** Hard Reset. This is accomplished by applying a hardware reset pulse to pin RST for 50 ms. The internal reset may be used by cycling the power. The modem should not be accessed for 500 msec after a reset has occurred.

IMPORTANT NOTE

Delay the sending commands to the CH1788 for a period of 500 msec after reset has been completed to allow the CH1788 time to properly reconfigure.

- Initial CH1788 Training. This will establish the word bit length and type for communication with the host. The word size should not be more than 10 bits including start and stop bits and is typically: 1 start bit, 1 stop bit, 8 data bits and with no parity. The CH1788 is trained by the host with the **AT<CR>**. The serial data rate (i.e., the DTE speed) at which the host sends the **AT<CR>** command initializes the modem DTE Speed.
- The CH1788 S registers must be re-configured to their required settings after a soft reset, hardware reset, or power loss.

THE COMMAND FORMAT

Typical commands consist of three elements: the attention sequence, the commands themselves, and a terminating carriage return.

AT[commands]<CR>.

Where: **AT** represents attention sequence.

[Commands] represents command strings.

<CR> represents carriage return (ASCII 13 or HEX 0D).

Training the Modem. The CH1788 must be trained to set the DTE speed (i.e., to match its host's speed and parity) so that the CH1788 is able to recognize serial asynchronous commands sent to it by the host's UART. The host must retrain the CH1788 each time a reset is performed.

Modem Training Command Sequence. The CH1788 is trained by sending it the **AT** sequence:

Enter: **AT<CR>**

Result: **OK**

Where: **A** and **T** may be either upper or lower case but must be the same case.

<CR> represents carriage return

The **AT** sequence is referred to as the attention sequence. When received, the CH1788 will respond with one of the following status messages, depending on whether the CH1788 is optioned for Terse (abbreviated) or Verbose (English) status messages.

Result: **0<CR>** (Terse)

or

Result: **<CR><LF>OK<CR><LF>** (Verbose)

Where: **<CR>** represents carriage return (ASCII 13 or HEX 0D).

<LF> represents line feed (ASCII 10 or HEX 0A).

After responding, the CH1788 will be in command mode and ready to accept additional commands. An alternate attention sequence **A/** may be sent. This command causes the previously entered command string specified with the **AT** prefix to be executed.

AT Command Set. The available commands are summarized in Table 5. Note that each command may have several options and the options may be influenced by various S-Register values. It is recommended that the designer review Cermetek publication CH1788 AT Commands and S-Registers Reference Guide.

AT Command Structure. When issuing commands to the CH1788, the backspace character-control-H (ASCII 8 or HEX 08) may be used to perform character editing.

Multiple commands may be placed on the command line as long as the command line does not exceed 63 characters, excluding the letters **AT**. By way of example, the command string below instructs the CH1788 to configure itself to suppress character echoing when in command mode **E0** and then put itself in the answer state **A**.

Enter: **ATE0A<CR>**

Result: **OK**

IMPORTANT NOTE

Allow a minimum of 125msec delay between subsequent **AT** commands.

MODEM STATES

The CH1788 is in either of two states: command mode or data mode. The CH1788 will only respond to **AT** commands when it is in command mode. When the modem is idle, by default it is in command mode.

When data transmission is in progress, the CH1788 is in data mode and will not recognize/respond to **AT** commands. To cause the CH1788 to recognize commands when in data mode, the host must send an escape sequence to the CH1788 forcing the CH1788 out of data mode and into command mode. Only then will the CH1788 respond to **AT** commands.

If the CH1788 is Off-Hook, connected to a remote modem and placed in command mode by its host, the CH1788 will not transmit any commands received from its host to the remote modem. However, when

in this state, the CH1788 will not receive data from the remote modem.

Result Codes. After execution of an **AT** command and at the completion of each dial attempt, the CH1788 will deliver a status message on RXD. Referring to Table 3, the message can be a Terse (numeric) or Verbose (English) message. The message type is controlled via the **V** command. Various combinations of the listed result codes can be selected with the **W** and **X** commands.

Table 3. Summary of Common Result Codes and Meanings.

Standard Result Codes		
Terse	Verbose	Meaning/Description
0	OK	Command Executed
1	CONNECT	Carrier detected at 300bps
2	RING	Ring Detected
3	NO CARRIER	Did not detect carrier
4	ERROR	Entry error
5	CONNECT 1200	Carrier detected at 1200bps
6	NO DIAL TONE	Off-hook, but no response after 5 seconds
7	BUSY	Busy signal detected
8	NO ANSWER	Remote modem did not answer
9	CONNECT 600	Connected, DTE to modem rate- 600bps
10	CONNECT 2400	Connected, DTE to modem rate- 2400bps
11	CONNECT 4800	Connected, DTE to modem rate-4800bps
12	CONNECT 9600	Connected, DTE to modem rate-9600bps
13	CONNECT 7200	Connected, DTE to modem rate-7200bps
14	LINE-IN-USE	When attempting to go off hook on a busy line
22	CONNECT 75/1200	V.23 or Bell 202 – forward/reverse channel
Extended Result Codes		
23	CONNECT 1200/75	V.23 or Bell 202 – forward /reverse channel
40	CARRIER 300	Modem (DCE) connect speed-300bps
41	CARRIER 600	Modem (DCE) connect speed-600bps
44	CARRIER 1200/75	Modem (DCE) connect speed-1200/75bps
45	CARRIER 75/1200	Modem (DCE) connect speed -75/1200bps
46	CARRIER 1200	Modem (DCE) connect speed-1200bps
47	CARRIER 2400	Modem (DCE) connect speed-2400bps

Escape Sequence. The escape sequence consists of a “guard time” of one second (a period where no characters are sent to the modem), followed by 3 escape characters (typically **+++**), followed by another guard time of one second. The escape character code is set in register S2. By default, the escape character is set as “+.” There is no required delay between characters. When the escape sequence has successfully been sent, the escape characters will not be transmitted to the remote modem.

The CH1788 will stay Off-Hook with its carrier on after the escape sequence is received. It will return an OK status message on RXD when it is ready to accept commands. The CH1788 may be put into data mode again by issuing the command **ATO**.

AT COMMAND APPLICATIONS

Dialing a phone number. The Dial command takes the form **Dn**, where **n** is a string of characters. In the simplest form, **n** will be the digits of the phone number to be dialed.

Example: Dial number.
 Enter: **ATD1234567<CR>**
 Result: **OK**

In the above example, the CH1788 dials the telephone number **1234567**, conducts handshaking negotiations then waits for a carrier from the distant modem. If a carrier is not detected within the time period specified by register S7, the CH1788 will automatically release the PSTN line and send the appropriate result code to the host. If a carrier is detected, the CH1788 will send the CONNECT result code and will permit communication with the distant modem. Note, the CH1788 is ready to send and receive data after the CONNECT result code is sent or when an active signal is present on DCD. DCD line must be enabled with the **ATC1** command.

A variety of dial modifiers can be placed in the dialing string to make it application specific. These include pause, hook flash, pulse dialing, wait for dial tone, etc. See the detailed **D** command.

The Dial Command may also be issued without a telephone number. **ATD** causes the modem to pick up the telephone line without dialing a number.

Programmable S-Registers. The CH1788 contains a variety of registers that store the configuration and personality parameters for the CH1788. Both default configuration and user specified configuration parameters are stored. A summary of the S-Registers is given in Table 4. A detailed description of each is available in CH1788 Command and S-

Register Reference Guide. Do not attempt to modify S-Registers that are not listed in the table.

Table 4. CH1788 S-Register Summary.

Register	Function
S0*	Ring to Answer On
S1	Ring Count
S2	Escape Code Character
S3	Carriage Return Character
S4	Line Feed Character
S5	Back Space Character
S6	Wait for Dial tone
S7	Wait for Data Carrier
S8	Pause Time for Comma
S9	Carrier Detect Response Time
S10	Lost Carrier to Hang-up Delay
S11	DTMF Tone On/Off
S13	DTMF Data/ Transmit Attenuation
S17	Ring Minimum Frequency
S18	Ring Maximum Frequency
S23	Call Progress Functions
S30	Data Modulation Selection
S31	Data Modulation Status
S51	Ring/ Cadence A minimum On-Time
S52	Ring/ Cadence A maximum On-Time
S53	Ring/ Cadence A minimum Off-Time
S54	Ring/ Cadence A maximum Off-Time
S55	Ring/ Cadence B minimum On-Time
S56	Ring/ Cadence B maximum On-Time
S57	Ring/ Cadence B minimum Off-Time
S58	Ring/ Cadence B maximum Off-Time
S65	DTMF Detection
S66	Wait For Dial Tone Timer
S67	Minimum Duration Of Dial Tone
S68	Test Timer
S69	Test Error Count
S86	Hook Flash On Time
S89	Fast Connect/Pickup
S95	Caller ID configuration
S110	Line-In-Use/ Parallel Pick-Up Register
S111	Line-In-Use Setting Time

Automatic Answering. Register S0 specifies the number of rings that the CH1788 must detect before it will answer. S0 may range in value from 0 to 255.

- S0 =0 DO NOT ANSWER TELEPHONE
- S0 =1 ANSWER ON RING 1
- S0 =2 ANSWER ON RING 2
- S0 =3 ANSWER ON RING 3
- S0 =255 ANSWER ON RING 255

When S0 is set to 0, the modem will not answer.

IMPORTANT NOTE

The tables included in this data sheet are a summary of the AT commands and S-Registers. A detailed description of all commands and registers is available from Cermetek Microelectronics, Inc., and should be consulted prior to design. Refer to Cermetek publication CH1788 AT Commands and S-Registers Reference Guide or access our website at <http://www.cermetek.com>.

Table 5. CH1788 AT Command Set Summary.

Basic Commands	Function
AT	Attention Code
A	Answer command
A/	Repeat last Command
C	Carrier Detect DCD Signal Monitor
D	Dial Command
E	Off-Line Character Echo Option
F	Load Factory Default
H	Switch Hook Control Option
I	Identification Option
K	DCE-DTE Flow Control
L	Fast Connect Option
N	Data Set Ready DSR Signal Monitor
O	On-Line Command
P	Pulse Dial
Q	Result Code Display Option
R	Data Terminal Ready DTR Monitor
S	S Register Monitor
T	Tone Dialing
V	Verbose / Numeric Result Codes
W	Extended Result Codes
X	Result Code Set/Call Progress
Y	Async. Speed Buffered Option.
Z	Reset
@T	Test Modes
@Z	Power Down
+++	Escape Sequence

PSTN LINE CONNECTION GUIDELINES

1. The CH1788 must be mounted in the final assembly such that it is isolated from exposure to any hazardous voltages within the assembly. Adequate separation and restraint of cables and cords must be provided.
2. The circuitry from the CH1788 to the telephone line interface must be provided in wiring that carries no other circuitry other than that specifically allowed in the FCC rules.
3. Connection to phone line should be made through an approved RJ-11C jack.
4. PCB traces from the modem's RING and TIP pins to the RJ-11C jack must be 0.1 inch spacing or

greater to one another and 0.2 inch spacing or greater to all other traces. The traces should have a nominal width of 0.020 inches or greater.

5. The RING and TIP PCB traces should be as short as possible and oriented to prevent coupling other high speed or high frequency signals present on the host circuit PCB.
6. No additional circuitry other than that shown may be connected between the modem module and the RJ-11C jack. Doing so will invalidate the FCC approval.
7. The CH1788 requires external surge protection. This is mandatory to maintain FCC Part 68 conveyed approval. Please use only recommended components and values. Do not use an MOV or a Transorb.
8. The CH1788, the RJ-11C jack, the protection circuitry and all PCB traces in between, must be contained on a PCB with a 94 V-0 flammability rating.
9. The supplied FCC registration label must be applied visibly on the outside of the product.
10. The product's User Manual must provide the user with instructions for connection and use as recommended in the FCC Registration Section below.

CH1788 HANDLING AND ASSEMBLY RECOMMENDATIONS

The CH1788 contains static-sensitive components and should only be handled by personnel and in areas that are properly protected against static discharge.

Direct Soldering. The CH1788 requires hand soldered. All CH1788 products are moisture resistant and will not be harmed by industry standard aqueous cleaning processes. Cermetek does NOT recommend SMD or wave soldering. Cermetek recommends against socketing the modem for production products. However, for development purposes, a 68 pin PLCC socket may be used.

FCC REGISTRATION

The CH1788 is registered with the FCC (Federal Communications Commission) under Part 68. To maintain the validity of the registration, the end product supplier must notify to the end user of the product of several restrictions the FCC places on the CH1788 and its use.

In addition to restriction notification, the FCC requires that Cermetek make all repairs to the CH1788. If repairs are necessary after installation of the CH1788 in the end product and the end product has been delivered to the end user, the end product must be returned to the end product supplier where the CH1788 can be removed and then forwarded to Cermetek for repair. The following notice is recommended and should be included in the end product's user manual.

FOR YOUR USER'S MANUAL

The FCC Part 68 rules require the following (or equivalent) be provided to the end user of equipment containing a registered element.

Type of Service. The (insert end product name) is designed to be used on standard device telephone lines. It connects to the telephone line by means of a standard jack called the USOC RJ-11C (or USOC RJ45S). Connection to telephone company provided coin service (central office implemented systems) is prohibited. Connection to party lines service is subject to state tariffs.

Changes in Attestation Procedure for Plugs and Jacks. (Name of applicant) attests that the network interface plugs or jacks used on this equipment comply with and will continue to comply with the mechanical requirements specified in Part 68, subpart F, specifically the dimensions, tolerances and metallic plating requirements. The compliance of these connectors will be assured by purchase specifications and incoming inspection. Documentation of such specifications and/or inspections will be provided to the FCC within 30 days of their request for same.

Telephone Company Procedures. The goal of the telephone company is to provide the best service it can. In order to do this, it may occasionally be necessary for them to make changes in their equipment, operations or procedures. If these changes might affect the service or the operation of equipment, the telephone company will provide notice, in writing, to allow time to make any changes necessary to maintain uninterrupted service.

In certain circumstances, it may be necessary for the telephone company to request information from you concerning the equipment which you have connected to your telephone line. Upon request of the telephone company, provide the FCC registration number and the ringer equivalence number (REN); both of these items are listed on the equipment label. The sum of all of the REN's on your telephone lines should be less than five in order to assure proper service from the telephone company.

If Problems Arise. If any telephone equipment is not operating properly, it should immediately be removed from the PSTN line, as it may cause harm to the PSTN network. If the telephone company notes a problem, they may temporarily discontinue service. When practical, they will provide notification in advance of this disconnection. If advance notice is not feasible, notification will be made as soon as possible.

If notified, the telephone company will allow the opportunity to correct the problem and will acknowledge your right to file a complaint with the FCC. Contact the local telephone service provider with any questions about the local PSTN line.

In the event repairs are ever needed on the (insert your product name), they should be performed by (insert your company name) or an authorized representative of (insert your company name). For information contact: (insert your company address).

DEFAULT STATUS, PERFORMANCE, AND SPECIFICATIONS

Table 6. Summary of the Default Configuration Profile of the CH1788.

Async speed buffer mode
2400bps
V22bis, V.22, V.21 operation
Eight bits, No parity
Auto answer disabled
Fast connect disabled
Flow control disabled
Command echo ON
All result codes enabled – non extended
Verbose result codes
DSR, DTR, DCD ignored by the modem
Guard tones disabled
Minimum DTR pulse width =0.1 seconds
Ring count =00
Escape code character =43 (+)
Carriage return character =13
Line feed character =10
Back space character =08
Duration of wait for dial tone =02 seconds
Duration of wait for carrier after dialing =50 seconds
Duration of dial pulse (comma)=02 seconds
Carrier detect response time =600ms
Escape code guard time =1 second
Last carrier to hang up delay =1.4 seconds
Flash on/off 500ms.
Ring frequency 10-75 Hz.
Power down idle mode inactivity on
Long space disconnect disabled

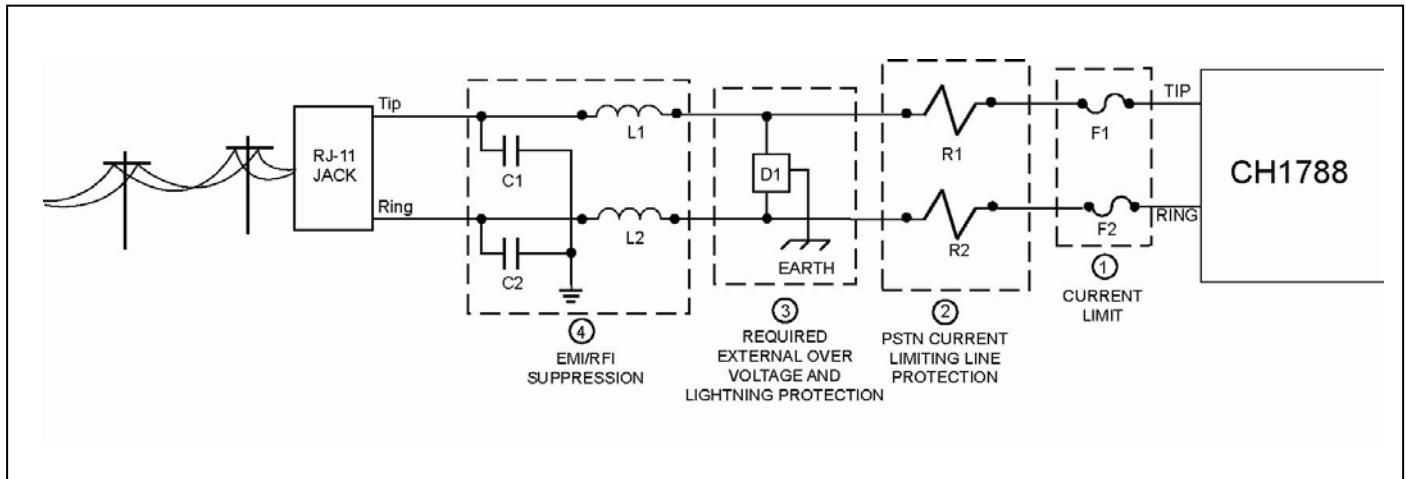

Figure 3. PSTN Line Interface for all CH1788 Products.

1. Current Limiting PSTN Protection Line Device.

Current limiting devices are mandatory to meet UL safety standards. To maintain conveyed FCC Part 68 approval, the current limiting components identified as F1 and F2 in dashed Box 1 must be included. Refer to Cermetek Application Note # 126, [Supplemental PSTN Line Protection](#), for more details. Refer to Cermetek Application Note # 130, [Summary of Recommended Suppliers](#), for a list of suppliers and manufactures part numbers.

A resettable/repairable fuse (rated at 0.15 amps) is preferred because it resets automatically upon removal of the current flow. Non-resettable devices are also acceptable. Although CSA CS-03 Part 1 (Canada) follows the requirements of FCC Part 68 (USA), Cermetek recommends contacting DOT (Canada) and/or a certified independent lab to verify compliance.

2. PSTN Current Limiting Resistors.

Low value (10Ω) 1/2 watt resistors may be required (identified as R1 and R2 in dashed Box 2), depending on end product application environment, to enhance performance by reducing susceptibility to PSTN current surges that may occur before the OVERVOLTAGE PROTECTION device (identified as D1 in dashed Box 3) becomes fully activated.

Refer to Cermetek Application Note # 130, [Summary of Recommended Supplies](#), for a list of suppliers.

3. Over Voltage and Lightning Protection.

To maintain conveyed FCC Part 68 approval for all CH1788 Products, the required surge protection must be supplied externally. It is required that a Sidactor or equivalent fast acting device be used. **DO NOT USE AN MOV OR A TRANSORB.**

The Sidactor or equivalent should be nominally rated at between 270-300 Volts. In most environments, 2 terminal surge suppressors are adequate. For severe environments, use an external 3 terminal device with an earth ground as is shown.

4. EMI/RFI Suppression.

EMI/RFI suppression is recommended. This is for obtaining FCC part 15 A and/or B. It is also used to suppress external EMI / RFI signals that can affect modem operation, such as strong radio signals, should the modem be near a source of such signals. No external EMI/RFI noise suppression circuitry is required to maintain conveyed FCC Part 68 approval. Additional suppression may be added as described below without adversely affecting FCC Part 68 approval.

- A. To provide adequate EMI/RFI suppression, the capacitor/inductor network contained in dashed Box 4 should be located as close to the RJ-11C Jack as possible. Further, this network should be provided with an excellent ground path to the chassis.
- B. Capacitors C1 and C2 should not exceed $0.005\mu\text{f}$. They must have a rating of 1.5KV and typically are $0.001\mu\text{f} \pm 20\%$. Inductors L1 and L2 may be either individual inductors or a dual inductor. Refer to Application Note #130 for a complete list of recommended vendors and associated part numbers. For UL applications, choose capacitors and inductors that are UL 1950 listed. The actual values of the components used may vary depending on the end product design and the nature of the EMI/ RFI. Consult an FCC part 15 consultant if required.

SCHEMATIC 1
Basic CH1788 Modem Implementation

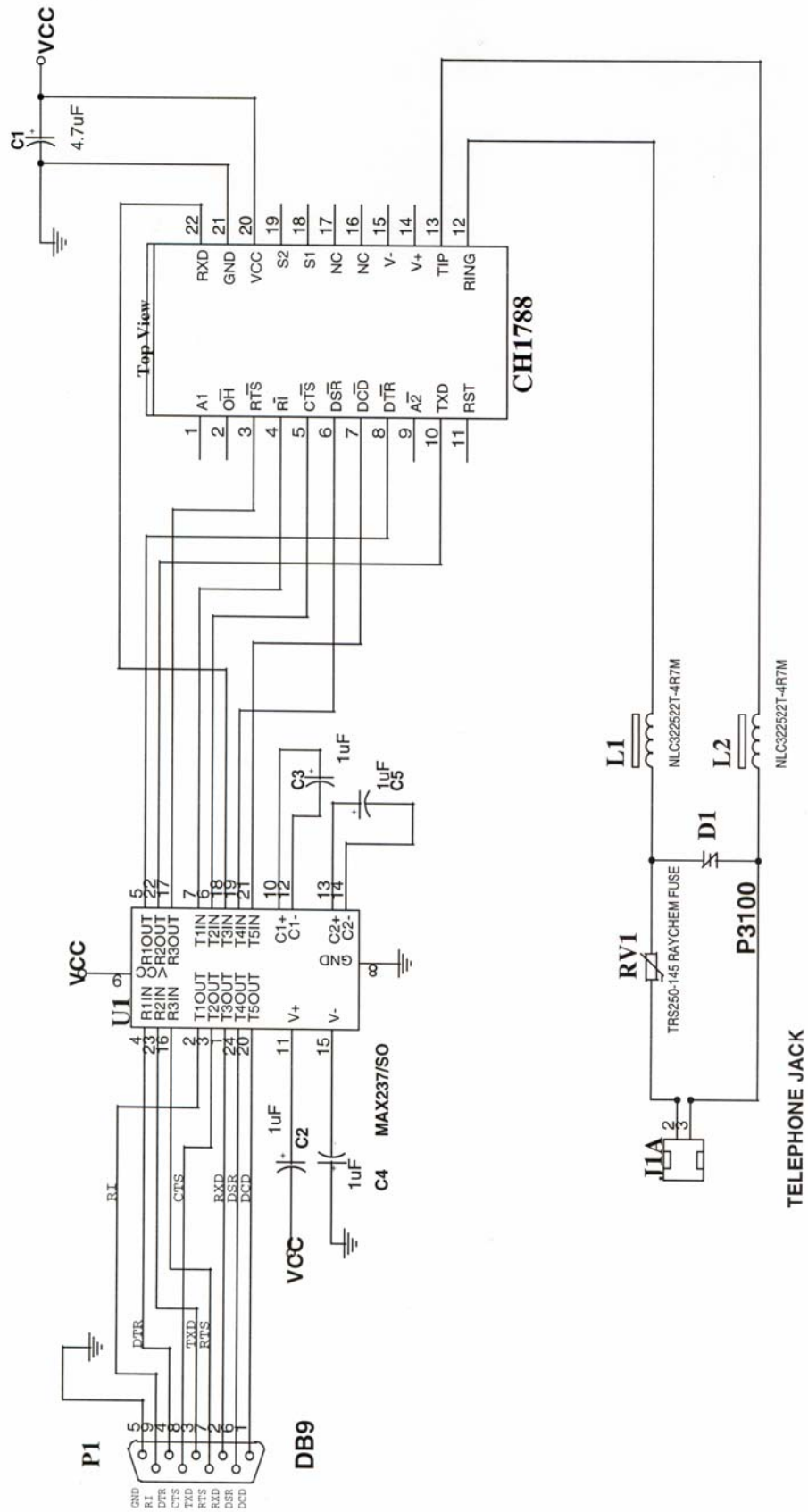

SCHEMATIC 2

CH1788 with Audio Monitor/DTMF Inject Implementation

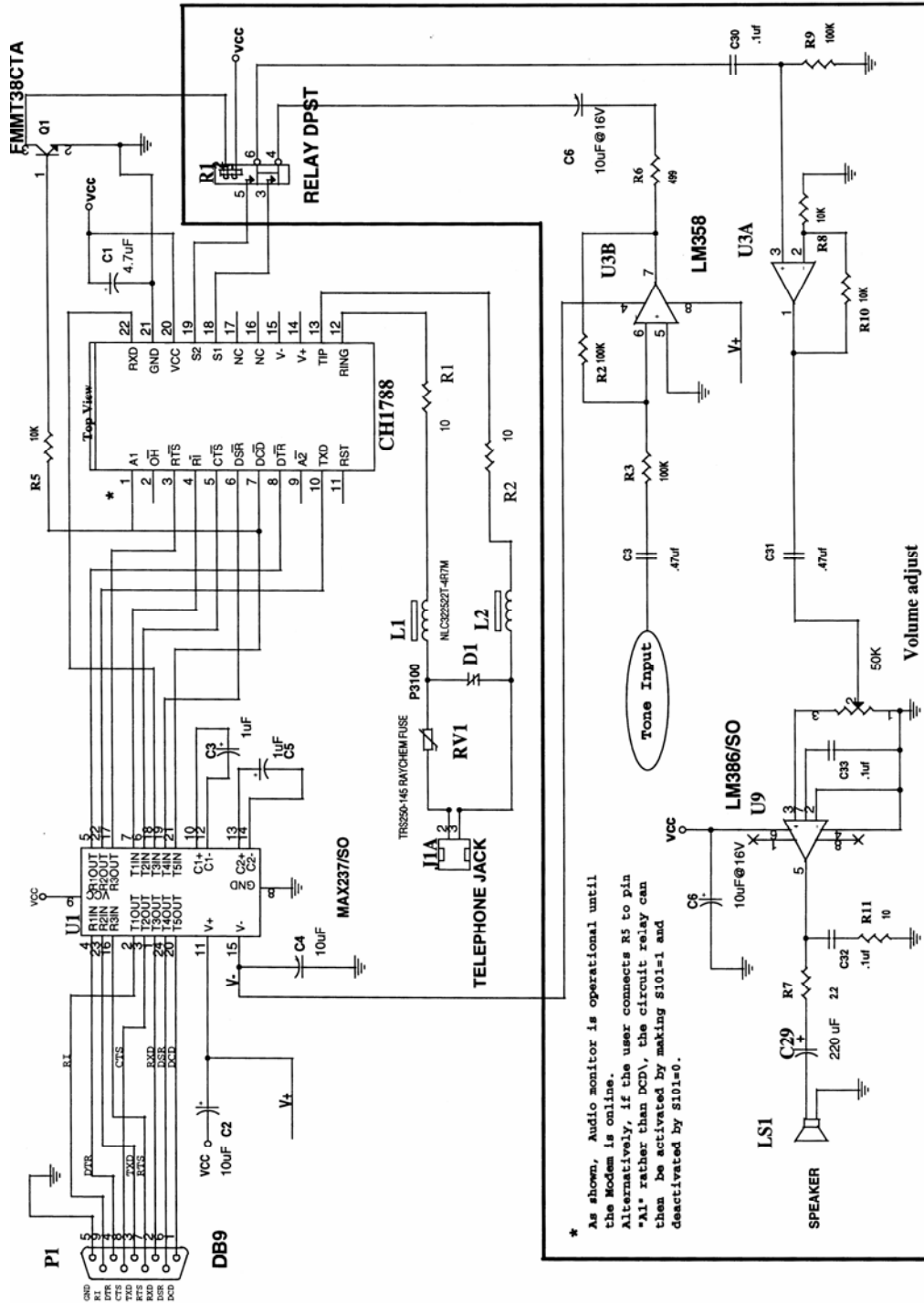

SCHEMATIC 3 CH1788 with Voice Injection Implementation

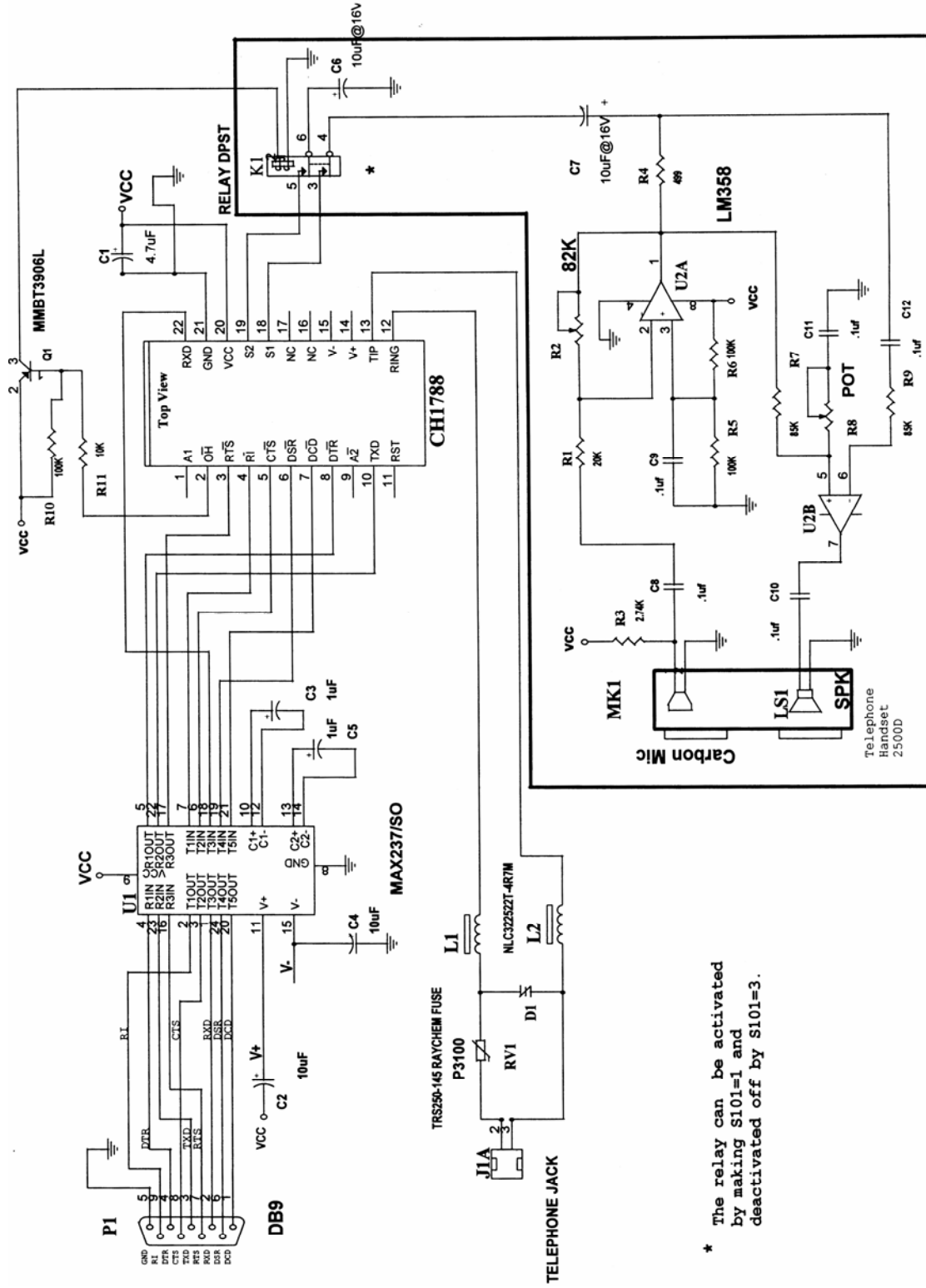

* The relay can be activated by making S101=1 and deactivated off by S101=3.

SCHEMATIC 4
CH1788 with Caller ID Implementation

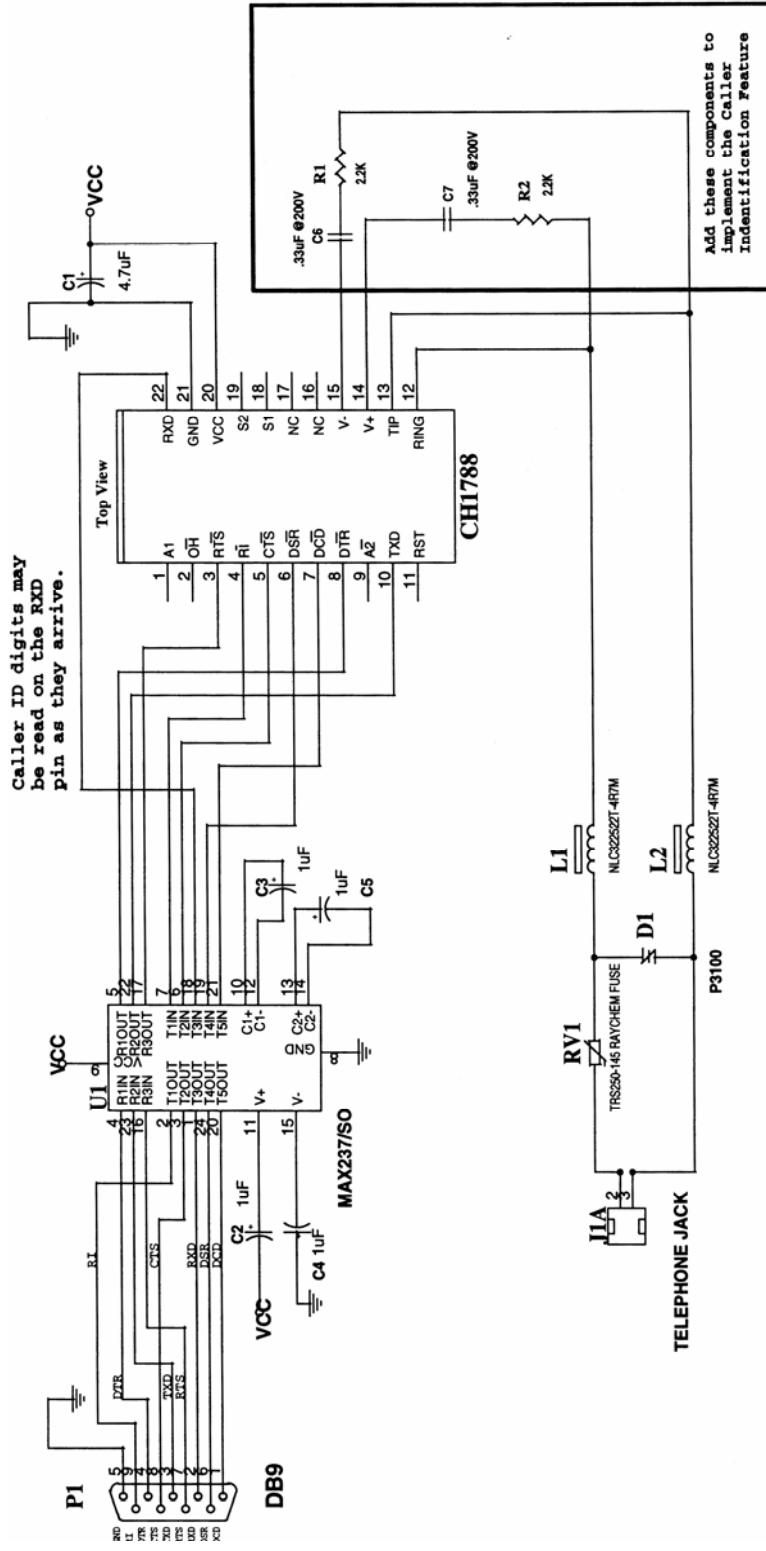

SCHEMATIC 5
CH1788 with Line In Use and Parallel Pick-Up Implementation (Voltage Sensing)

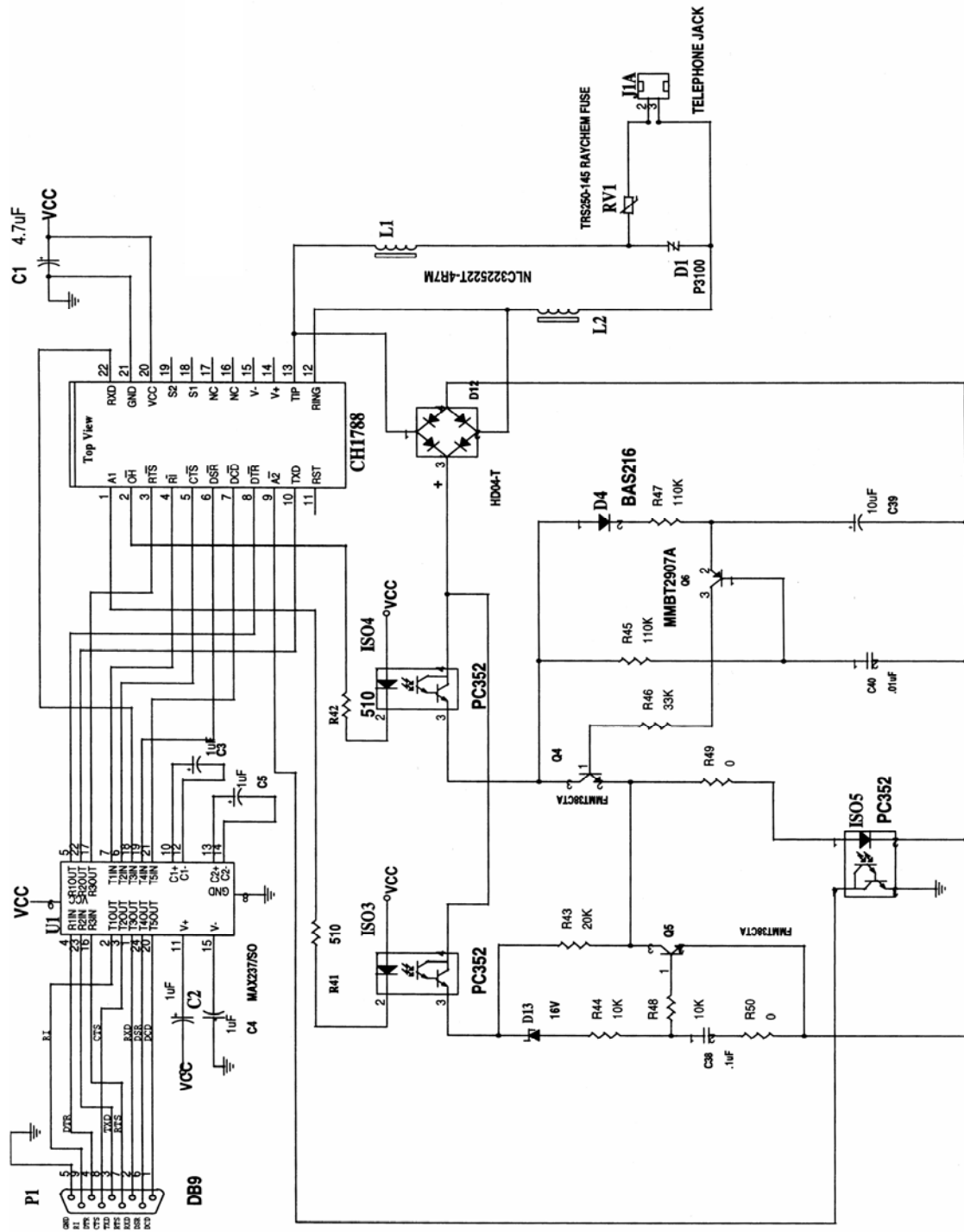

CH1788 with Line In Use and 911 Priority Pick-Up Implementation (Current Sensing)
SCHEMATIC 6

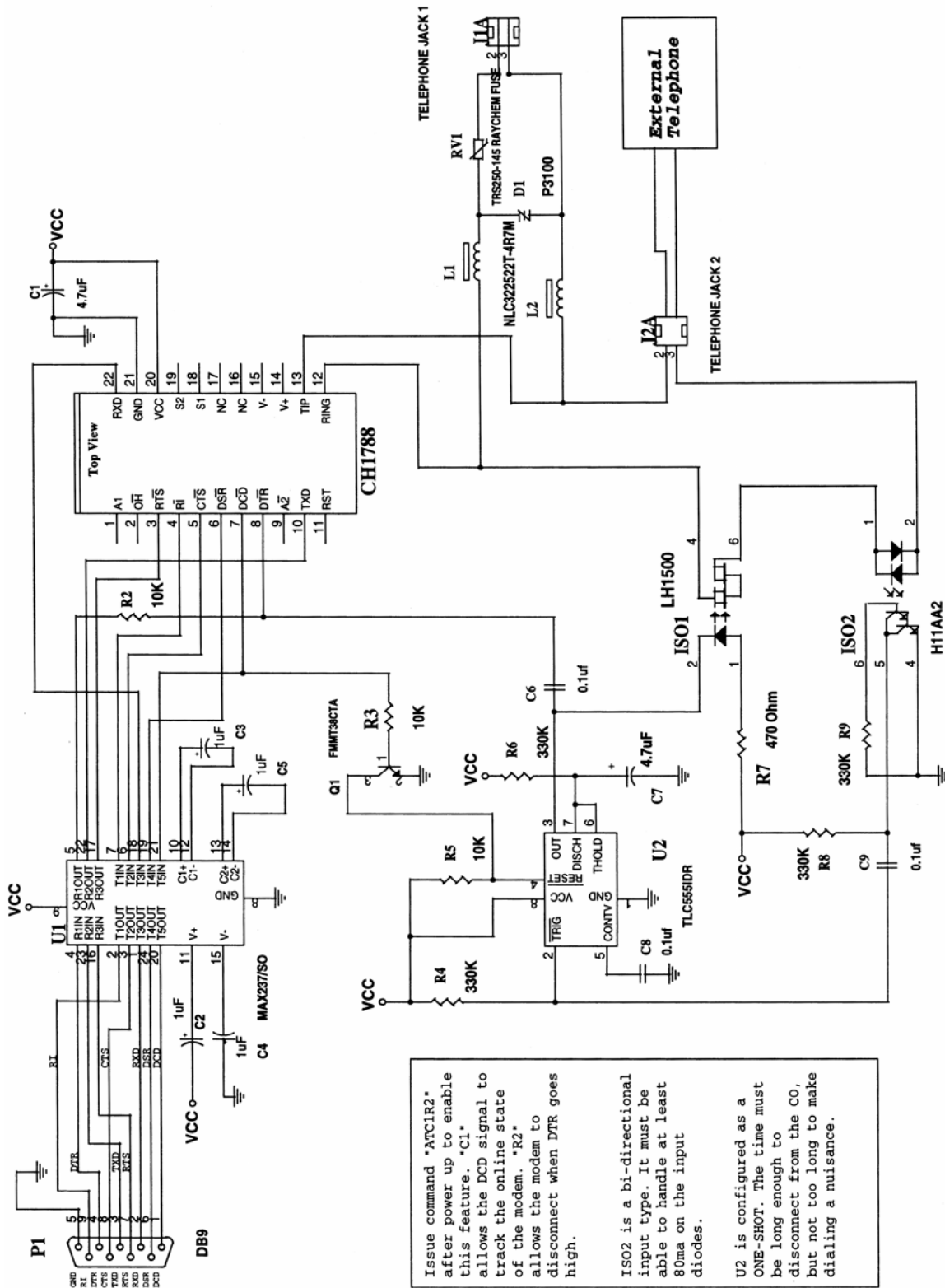

Issue command *ATC1R2* after power up to enable this feature. *C1* allows the DCD signal to track the online state of the modem. *R2* allows the modem to disconnect when DTR goes high.

ISO2 is a bi-directional input type. It must be able to handle at least 80ma on the input diodes.

U2 is configured as a ONE-SHOT. The time must be long enough to disconnect from the CO, but not too long to make dialing a nuisance.

SCHEMATIC 7
Suggested circuit to interface RS-232 logic to CH1788 TTL V.24 logic.

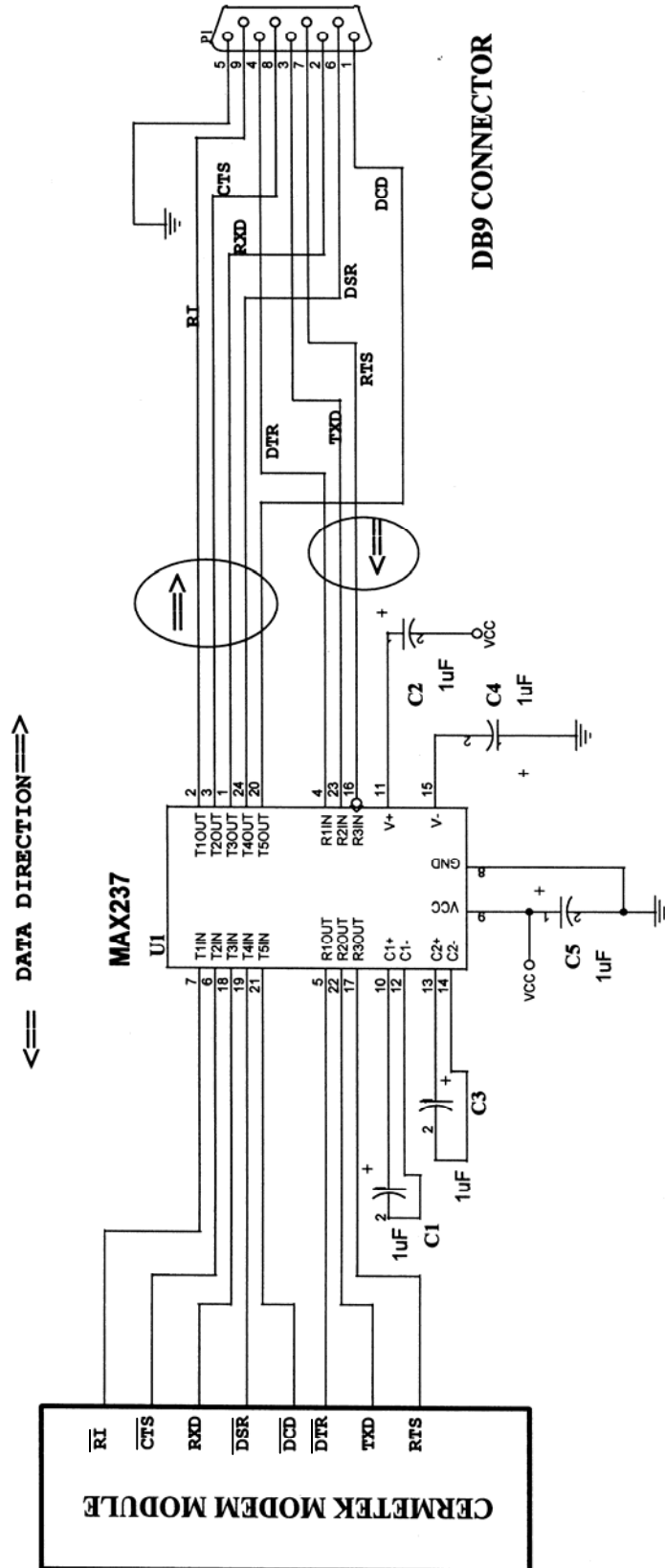

Table 7. CH1788 System Data Mode Compatibility Specifications.

Parameter	Specification	Parameter	Specification
Asynchronous	2400, 1200 bps character asynchronous. 300 bps asynchronous	Receive Carrier Frequencies V.22 bis, V.22, 212A	Originate 2400Hz \pm 7Hz Answer 1200Hz \pm 7Hz
Asynchronous Speed Range	TXD may differ +/-2.5% from modem output. Offsets will be corrected by adding/ deleting stop bits.	Bell 103	Answer 'space' 2020Hz \pm 7Hz Answer 'mark' 2225Hz \pm 7Hz Originate 'space' 1070Hz \pm 7Hz Originate 'mark' 1270Hz \pm 7Hz
Asynchronous Format	10 bits, including start, stop, parity.	Receiver Sensitivity	Carrier detect ON threshold -43dBm Carrier detect OFF threshold -48dBm
Telephone Line Interface	Two-wire full duplex over public switched network. On-chip hybrid and billing delay timers.	Billing Delay	2.0 to 3.0 seconds
Transmit level	V.22 bis, 16 point QAM at 600 baud. V.22 and 212A, 4 point DPSK at 600 baud. 103 Binary phase coherent FSK.	Power	-9.6dB max-QAM -7.4dB max.-DPSK -5.3dB max-FSK
Self Test Pattern Generator	Alternate 'ones' and 'zeros' and error detector, to be used along with most loopbacks. A number indicating the bit errors detected is sent to DTE.	Line Equalization	Fixed compromise equalization, transmit. Adaptive equalizer for DPSK/QAM, receive.
Transmit Carrier Frequencies V.22 bis, V.22, 212A	Originate 1200Hz \pm .01% Answer 2400Hz \pm .01%	Diagnostic Available	Local analog loopback. Local analog loopback. Remote digital loopback. Request remote digital loopback. Local interface loopback modem with self-test.
Bell 103	Originate 'space' 1070Hz \pm .01% Originate 'mark' 1270Hz \pm .01% Answer 'space' 2020Hz \pm .01% Answer 'mark' 2225Hz \pm .01%	Call Progress Tones Detected Computer Interface	With speaker or quiet screen messages (No dial tone, busy, ring-back, modem answer tone and voice).

Table 8. CH1788 D.C. Electrical Specifications.

Parameter	Description	Min.	Typ.	Max.	Units	
V _{CC}	Positive Supply Voltage- Noise less than 50mV	5V 3.3V	4.75 2.70	5.0 3.30	5.3 3.60	V
I _{dd1}	Nominal Operating Current	5V 3.3V		51	62 16	mA
I _{dd2}	Power Down Idle mode Current	5V 3.3V			3.0 2.5	mA
I _{dd3}	Power Down "Zero" Mode Current	5V 3.3V			15 10	uA
V _{IH}	High Level Input Voltage*	5V 3.3V	V _{CC} /2 0.2 V _{CC}		+5.5	V
V _{IL}	Low Level Input Voltage*	5V 3.3V			.50 0.2 V _{CC}	V
I _{IN}	Input Leakage Current – All Pins				1	uA
V _{OH}	High Level @ -4mA 5V and 3.3V		V _{CC} -0.45			V
V _{OL}	Low Level @ 4mA	5V 3.3V			0.6 0.45	V
Test conditions: CH1788 VCC = 5V ± 10%, Temp = 0°C to 70°F. CH1788-3 VCC = 3.3V ± 10%, Temp = 0°C to 70°F *Output Load = 30 pF ± one TTL.						

Table 9. CH1788 Operational Specifications.

Parameter	Minimum	Typical	Maximum	Units	Comments
Off Hook Impedance		600		Ohms	
Trans Hybrid Loss		25		dB	600 Ohm, RXA, TXA
Ring Voltage Loop	110V		250V	V _{pp}	On 48VDC line voltage offset for sustained periods of seconds.
Line Loop Current-(Off-Hook)		20	80	mA	
Return Loss @ 1000Hz		15		dB	600 Ohm
Ring Frequencies	10	20	75	Hz	
Receiver Insertion Gain	-0.5	0.0	+0.5	dBm	600 Ohm- Data Mode
Transmit Power		-10.0		dBm	When recommended initialization is used.
First Character After Reset	0.5	2.0		sec	Delay
Inter Character Delay	0	50		msec	Between all command characters
Command Delay	125	150		msec	Between all AT commands
Minimum Reset Pulse Duration	50			msec	If user supplied

Table 10. Other Performance Specifications.

Parameter	Minimum	Typical	Maximum	Units	Comments
Tone 2 nd Harmonic Distortion			-35	dB	HYB enabled into 600Ω
DTMF Twist (Balance)		2		dB	
DTMF Tone Duration	50		255	ms	95ms default
Pulse Dialing Rate	8	10	20	pps	10pps default
Pulse Dialing Make/ Break		39/61		%	US, Canada default
Pulse Interdigit Interval	700		3000	ms	789ms default
Guard Tone Frequency		550		Hz	Referenced to High Channel Transmit
Guard Tone Amplitude		-6		dB	Referenced to High Channel Transmit
Guard Tone Frequency		1800		Hz	Referenced to High Channel Transmit
Guard Tone Amplitude		-9		dB	Referenced to High Channel Transmit
High Channel Transmit Amplitude		-1		dB	Referenced to Low channel, Guard tone enabled
Guard Tone 2 nd Harmonic Distortion		-40		dB	
Call Progress Passband Frequency	120		620	Hz	
Wait Time for Dial tone	2		255	sec	Two second default
Return loss @ 1000Hz		30		dB	$T_r=600\Omega + 2.16 \mu F$

Table 11. Summary CH1788 Family of Products.

Model	Summary of Features	Operating Temperature
CH1788	5V, Full function, FCC Part 68 approved, UL 1950 Listed, Hermetic	0°C to 70°C
CH1788ET	5V, Full function, FCC Part 68 approved, UL 1950 Listed, Hermetic	-40°C to 85°C
CH1788-3	3.3V, Full function, FCC Part 68 approved, UL 1950 Listed, Hermetic	0°C to 70°C
CH1788-3ET	3.3V, Full function, FCC Part 68 approved, UL 1950 Listed, Hermetic	-40°C to 85°C

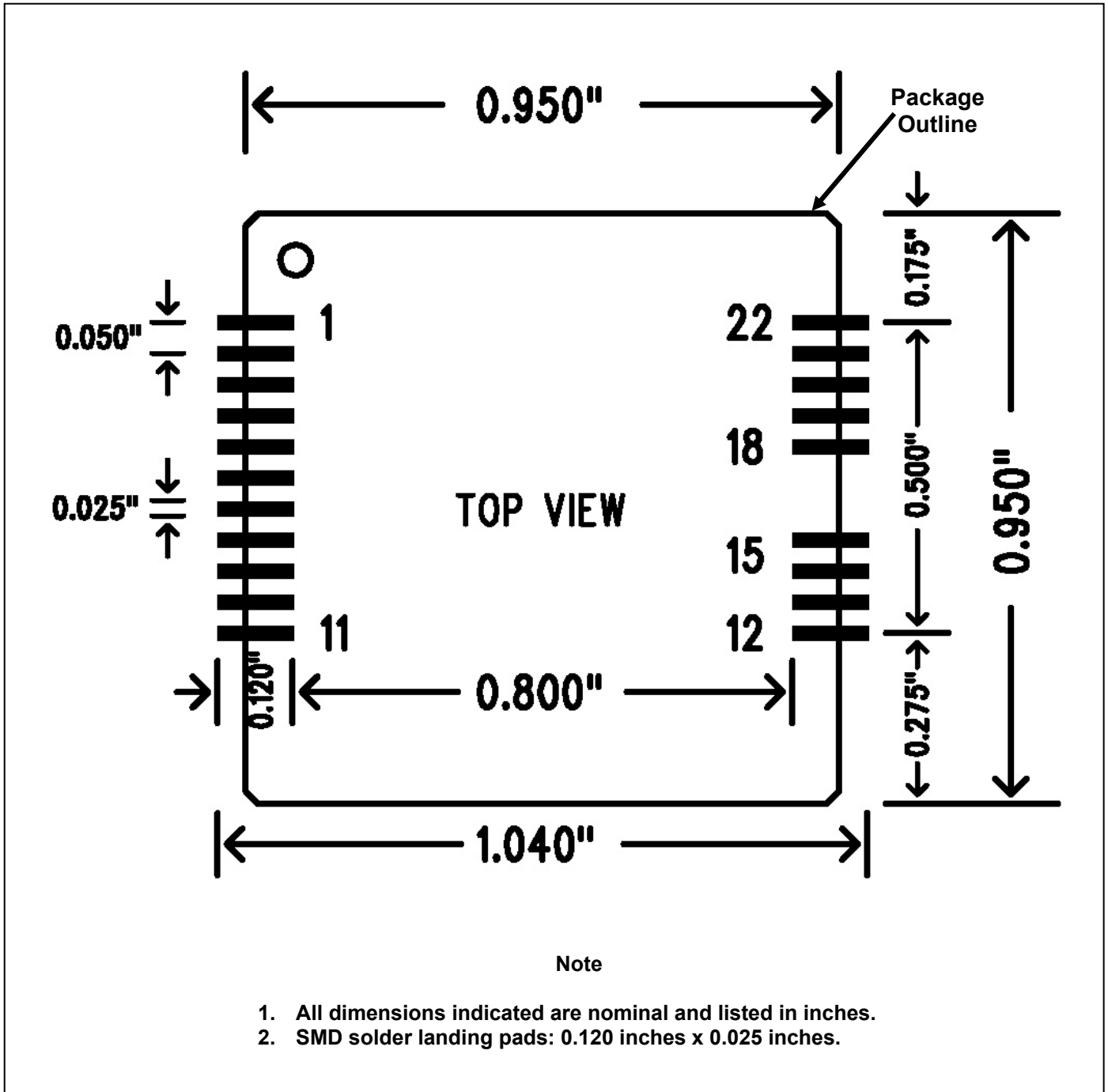

Figure 4. Recommended CH1788 PCB Layout Footprint.

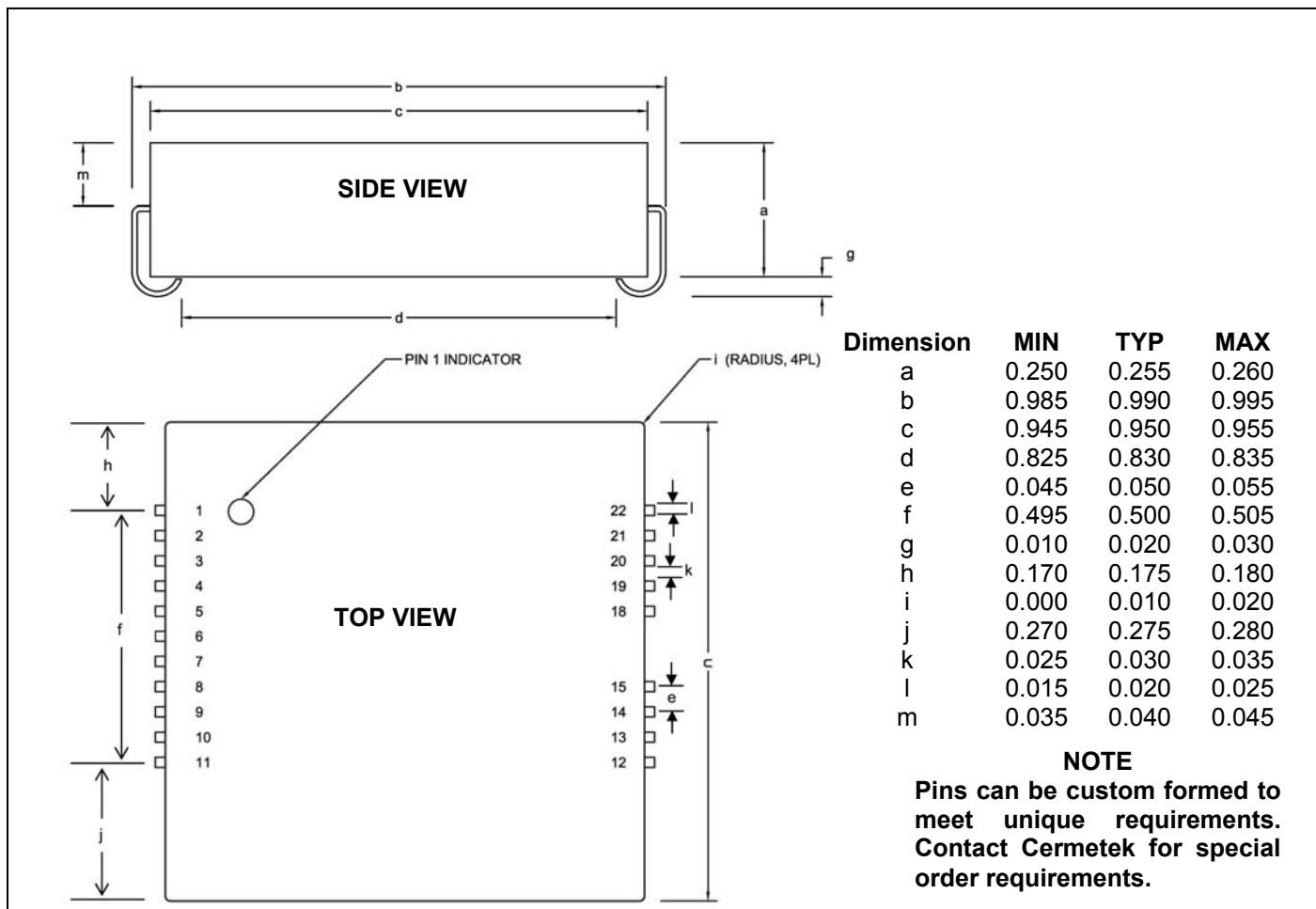

Figure 5. CH1788 Physical Dimensions.

Table 12. CH1788 Pin Functions.

PACKAGE CONNECTION TABLE			
PIN NO.	FUNCTION	PIN NO.	FUNCTION
1	A1	12	RING
2	OH *	13	TIP
3	RTS*	14	V+
4	RI*	15	V-
5	CTS*	16	OPEN
6	DSR*	17	OPEN
7	DCD*	18	S1
8	DTR*	19	S2
9	A2*	20	V _{CC}
10	TXD	21	GND
11	RST	22	RXD

* Active Low

Cermetek reserves the right to make changes in specifications at any time and without notice. The information furnished by Cermetek in this publication is believed to be accurate and reliable. However, Cermetek assumes no responsibility for its use, or for any infringements of patents or other rights of third parties resulting from its use. No license is granted under any patents or patent rights of Cermetek.

Cermetek provides the user with a FCC (USA) and IC (Canada) Approved or Approvable device. However, Cermetek does not have influence over nor knowledge of the specific user application environment. Therefore, for FCC and IC Approved or Approvable devices, the user assumes all risk for maintaining compliance to registration.

Printed in U.S.A